

ABSTRACT

Title of dissertation: THEMATIC RELATIONS BETWEEN NOUNS

Juan Carlos Castillo, Doctor of Philosophy, 2001

Dissertation directed by: Professor Juan Uriagereka
Department of Linguistics

This dissertation explores some of the traditionally labeled possessive relations, and proposes a basic syntactic structure that underlies them. The two nouns act as subject and predicate in a small clause, dominated by two functional projections, where reference/agreement and contextual restrictions are checked.

Looking first at container-content relations, we propose that the container is always a predicate for the content. Because in our system selection is determined in the small clause and agreement is checked in an AgrP, selection and agreement need not be determined by the same noun. Selection also distinguishes between a container and a content reading. The evidence from extraction shows that container readings are more complex than content readings. We propose that the container reading adds a higher small clause whose predicate is the feature number.

Number is thus a predicate, which type-lifts mass terms to count nouns, the way classifiers do in languages without number. Evidence from Spanish and Asturian shows a three-way distinction between absence of number (mass terms), singular and plural. We also propose that nouns are not divided into rigid classes, such as mass/count. Rather, any noun may be used as mass or count, depending

on whether number is added to its syntactic derivation or not.

An analysis of possessor raising to both nominative and dative in Spanish also supports the idea that nouns are not divided into rigid classes with respect to their ability to enter possessive relations. Relations such as part/whole, alienable and inalienable possessions, are all analyzed as small clauses where the possessor is the subject and the possessed is the predicate.

Finally, we propose a universal principle: possessor raising can occur in languages that have a structural Case in a v-projection, in addition to the Case checked by the direct object. This predicts that causative verbs in languages with possessor raising should also allow the Case checking of both the object and the subject of an embedded transitive clause. The prediction is borne out, giving rise to four types of languages, according to their Case system.

THEMATIC RELATIONS BETWEEN NOUNS

by

Juan Carlos Castillo

Dissertation submitted to the faculty of the Graduate
School of the University of Maryland at College
Park in partial fulfillment of the
requirements for the degree of
Doctor of Philosophy
2001

Advisory Committee:

Professor Juan Uriagereka, Chair
Professor Stephen Crain
Professor Norbert Hornstein
Professor David Lightfoot
Professor Paul Pietroski
Professor Corey Washington

©Copyright by

Juan Carlos Castillo

2001

A mis padres, los mejores directores en la tesis de la vida
To my parents, the best directors in life's dissertation

ACKNOWLEDGMENTS

This dissertation would not have been possible without the inspiration, support and patience provided by my advisor, Juan Uriagereka. My work is nothing but a continuation of his brilliant ideas, an intuition I am still pursuing. His enthusiasm has kept me going through the bad times, and his example still guides my career.

I also want to thank the rest of the members in my committee. Norbert Hornstein is quite possibly the best teacher I know, and his careful criticism always takes you one step further. David Lightfoot taught me to think of deeper issues than just the pure analysis of the data. Stephen Crain is a model of discipline and care in the research enterprise. Although they were late additions to my student career at Maryland, I also thank Paul Pietroski and Corey Washington for their help and ideas.

Nothing would have been the same without my colleagues at Maryland. In a more or less chronological order, I want to mention my classmates Will Corbin, Haruka Fukazawa, Pat Hironymous, Akemi Matsuya, Viola Miglio, Frida Morelli, Bruce Morén and Julien Musolino. They all helped me through my first times at Maryland, when we were lost and overwhelmed.

Many of the veteran students welcomed me and helped me feel at home. Among them, I especially want to thank Mark Arnold, Jairo Nunes, Christina Schmitt, Ellen Thompson, and

Spiridoula Varlokosta, who always treated me like one of them.

I had the privilege of getting to know some of the best linguists in my generation. From John Drury I have learned everything from playing guitar to how to order eggs at a diner, but most of all, our conversations on linguistics still are the best source of motivation I can find. Ricardo Etxepare has been the best example of professionalism and discipline I have ever known, and still is my model of the perfect scientist. Kleantes Grohmann has taught me his enthusiasm without limits. Tonia Bleam, Cedric Boeckx, Jenny Doetjes, Eric Groat, Nobue Mori, Keiko Muromatsu, Paco Ordóñez, Javi Ormazabal, Miriam Uribe-Etxebarria and so many more have inspired me with their work and ideas.

One cannot go through a PhD without the help of close friends, colleagues and roommates. Caro Struijke and Jeff Lilly have always shared everything with me. The Basque connection, personified by Aitziber Atutxa, Elixabete Murgia and Itziar San Martín, always make me feel at home at home. Laura Benua is more of a friend than a professor. Lisa Dix, John Engel, Jenny Graham, Matt and Bridgette Kaiser, Chris Schrumm, and all of those who let me be a part of their lives. Thank you all.

I also want to thank the people who got me started in linguistics before my Maryland days: Carmen Isasi at Deusto; especially Paula Kempchinsky and Bill Davies, but also Rob

Chametzky, Alice Davison and Nora González at Iowa; Doug Jones during his short stay at Maryland.

This dissertation has been made possible by the generous financial support from the Basque Government's Department of Education, University and Research (pre-doctoral scholarship BFI94.036) and the Department of Linguistics at Maryland.

Finally, I want to acknowledge the people who made me who I am: my parents, Angel and Amelia, and my wife Jenny. It is to their support and love that I owe my whole career and life.

TABLE OF CONTENTS

Chapter 1: Introduction	1
1 Types of Possessive Relations	1
2 Types of Possessive Constructions	4
2.1 Relational Grammar and Possessor Ascension	4
2.2 The Possessor that Ran Away from Home	9
2.3 Auxiliary Selection and Possession	12
2.3.1 Locatives, Existentials and Possessives	12
2.3.2 Possessive Auxiliary Derivation	15
2.3.3 Integrals	18
2.4 Warps	28
3 Outline of the Dissertation	32
 Chapter 2: The Syntax of Container-Content Relations	 35
1 Container-Content DPs	36
1.1 The Concept of Head	36
1.2 Thematic Relations	41
1.3 Extraction and the Container-Content DPs	43
1.4 Conclusion	46
2 A New Proposal	47
2.1 The Content Reading	52
2.1.1 Argumenthood of the Content	53
2.1.2 Derivations of Content Readings	56
2.2 The Container Reading	57
2.3 Back to the Content Reading	61
2.4 Conclusion	64
3 Extraction Out of DPs	65
4 Further Extensions of the Analysis	69
5 Conclusion	73
 Chapter 3: Measures to Parts, Mass to Count	 75
1 From Mass to Count	75
2 More Contrasts	77
2.1 Measures vs. Parts	77
2.2 Quantifiers vs. Measures	79
2.3 Singular vs. Plural	80
3 An Analysis	81
3.1 Classifiers and Number	81
3.2 Absence of Number	84
3.3 Singular vs. Plural Differences	86
3.4 Warping and Non-Warping Presentations	89
3.5 Mass Nouns and Count Nouns?	89
4 The Number Warp	91
4.1 Previous Accounts of Number	91
4.2 Number as a Conceptual Warp	94
4.3 The Scope of Number	96
4.4 The Syntactic Nature of Number	99
5 Conclusion	102

Chapter 4: Possessor Raising in Spanish	103
1 Possessive Relations	105
2 Possessor Raising	107
2.1 A Description	107
3 Clitic Doubling and Possessor Raising	109
3.1 Clitic Doubling with <i>la</i>	113
3.2 Clitic Doubling with <i>le</i>	115
3.3 Possessor Raising with <i>le</i>	117
3.4 Affectedness, Animacy and Other Restrictions	118
3.5 Conclusion	120
4 Raising to Subject	120
4.1 Subject Possessor Raising	122
4.2 Subject Clitic Doubling	123
4.3 Consequences of the Analysis	125
4.3.1 Obligatory Inalienable Reading	126
4.3.2 Obligatory Object	127
4.3.3 Lack of Cognate Object	132
4.3.4 Lack of Verbal Passives	132
4.3.5 Light Verb Constructions	134
4.4 Conclusion	135
5 The Nature of Different Possessive Relations	135
5.1 Transitive vs. Intransitive Possessive Relations	135
5.2 The Argument Structure of Nouns	136
5.2.1 Classes of Nouns	137
5.2.2 Inherently Relational Nouns	138
6 A Case Study: Possessor Raising in Spanish and Different Possessive Relations	142
6.1 Kinship	145
6.2 Transitive Part-Whole	151
6.3 Intransitive Part-Whole	156
6.4 Alienable Relations	160
6.5 Conclusion	162
7 Conclusion	163
 Chapter 5: Towards a Universal Account of Possessor Raising	 164
1 Possessor Raising	167
1.1 A Description	167
1.2 The Possessor Raising Condition	168
1.3 Independent Evidence I: Ditransitive Verbs	169
1.4 Independent Evidence II: Causatives of Transitive Verbs	170
2 Typology of Languages	173
2.1 Type 1: Languages without Possessor Raising	174
2.2 Type 2: Languages with Object Incorporation	176
2.3 Type 3: Languages with Double Accusative	178
2.4 Type 4: Languages with Possessor Raising to Dative	180
2.5 Conclusion	184
3 The Locus of Case Checking and Parametric Variation	184
3.1 Type 1 Languages	186
3.2 Type 2 Languages	187

3.3 Type 3 Languages	190
3.4 Type 4 Languages	193
3.5 The 3-Chomeur Ban	196
4 Conclusion	197
Chapter 6: Future Lines of Research	199
References	202

LIST OF TABLES

1	Typology of languages according to the PRC	173
---	--	-----

CHAPTER 1
INTRODUCTION

This dissertation studies several syntactic realizations of sentences which contain a thematic relation directly established between two nouns. In the linguistic tradition, relations between nouns are called *possessive*, probably due to the fact that relations of ownership are typically realized in this way.

1 Types of Possessive Relations

In this section, I will discuss the different thematic relations that possessive constructions may represent. Some examples are provided in (1):

- (1) a. John's sister.
b. John's arm.
c. The truck's doors.
d. John's car.

Spanish

- e. Esta botella tiene cerveza.
this bottle has beer
f. Juan tiene vergüenza/hambre/altura /conocimiento
J has shame hunger height knowledge

Tzotzil

- g. 7icham xa latzekale (Aissen 1987:129)
died cl Agr-scorpion-Poss-cl
'Your scorpion (e.g. the one that bit you) has
already died.'

For the time being I will not discuss the different forms in which possession is expressed in (1). Instead, I want to discuss the different kinds of relations

involved. In all cases, there are two nouns, one of which can be characterized as the possessor and the other as the possessed, but the actual relation between the two varies from expression to expression.

(1)a is a typical instance of kinship term. One of the two nouns describes the family relationship (sister, in this case) that the referent of the whole expression bears with respect to the other noun (in this instance, John).

(1)b represents the relation between a whole (John) and one of its parts (his arm). This type of relation receives different names in the linguistic tradition. Sometimes it is referred to as the part-whole relation. We also find the term inalienable possession being used to describe it. Inalienable relations, as opposed to ownership, cannot be altered or disrupted.

(1)c is the same instance as (1)b, but having an inanimate whole (the truck). The fact that the part-whole or inalienable relation can be applied to inanimate beings somehow underscores the inappropriateness of the term possession, since inanimate objects cannot own anything. However, I will switch between the names of part/whole and the more traditional inalienable possession when talking about this kind of relation.

(1)d is the paradigmatic example of alienable possession or ownership. The possessor (John) is understood as a temporary owner of the possessed term (the car), but the relation has the potential of being altered over time, so that the same car could become someone else's. As we will see in this dissertation, the difference between alienable and inalienable (or part-whole) possession is syntactically marked in many

languages, suggesting that they are considered different thematic relations. Also, alienable possession seems to be generally restricted to animate possessors across languages. This is another difference with the inalienable or part-whole relation, which, we saw, can be applied to both animate and inanimate possessors.

(1)e represents a container-content relation. In this case, the possessed noun (the beer) is not a part of the possessor (the bottle), but rather it is spatially contained in it. As I will argue in this dissertation, this relation seems to be restricted to mass interpretations of the possessed, which is not conceived of as an individual.

(1)f (mostly taken from Uriagereka 1996:154) shows that possessive constructions can also represent properties such as emotional, physical or mental states. Since these states can be expressed using nouns, the noun undergoing them can be expressed as a possessor of the possessed property. Some of these properties are permanent, whereas others are transient, and the possessors may be animate or inanimate, but they all can be constructed using a possessive expression.

Finally, the Tzotzil example in (1)g shows how a possessive construction can be used to express almost any relation between nominals relevant in context. In this instance, the relation between the two nouns is neither ownership, nor inalienable possession or container-content. It simply expresses a contextual connection between the two nouns.

Of course, trying to subsume all these different relations under a simple 'possessive theta-role' label is too much of a simplification. Also, it is not clear that

there is any lexical head that may mediate the relation between the two nouns. It is very likely that the interpretations stem from the semantic relations between the nouns, rather than from heads assigning different theta-roles.

In the following section, I will discuss the recent developments in the syntax of possessive relations, and how these analyses influence the work in this dissertation.

2 Types of Possessive Constructions

This section will look at some syntactic forms that a possessive relation may take in different languages. I will present the different analyses that have been proposed to analyze these constructions, and how these analyses will bear on the ideas defended in this dissertation.

2.1 Relational Grammar and Possessor Ascension

In this section, I will present the initial analyses that Relational Grammar (henceforth, RG) proposes for the raising of possessors out of their initial constituents.

I will assume the intuition expressed by Fox (1981) that Possessor Raising (PR) structures appear in instances in which a whole and a part hold different surface grammatical relations (GRs) with respect to the same verb. Fox claims that, at least in some instances, the presence of part-whole dependencies decreases the argument valence of the verb, so that a verb with, say, three GRs in the surface, as in the Spanish sentence (2), will actually have only two at the conceptual level.

- (2) a. Surface structure:
 [Juan] le levantó [la mano] [a María]
 J cl lifted the hand to M
 'Juan lifted Maria's hand'
- b. Conceptual structure:
 [Juan] levantó [la mano [_{POSS} María]]

Thus, given that in the deep structure the whole and the part are not two separate arguments, this means that one of them has been raised from an embedded constituent to a matrix GR.

In general, it is understood that the possessor is the one that is raised. This is understandable, given that the possessor in many cases is not a participant in the verb's event. In certain instances, there may even be a selection clash between the features of the possessor and those required for the verb for its argument, as in the following Spanish example:

- (3) Juan le bebió la cerveza a María
 J cl drank the beer to M
 'Juan drank María's beer'

The verb *beber* 'drink' requires an internal argument with the semantic feature [+liquid] in order to produce a pragmatically correct sentence. Only the possessed noun ('beer') can satisfy this requirement, which means that it is the possessor ('María') that moves to its surface position, and is not a thematic argument of the verb.

The literature in the RG framework studies a series of languages in which a possessor does not appear in the surface in the same constituent as the possessed, but rather occupying a grammatical relation with respect to a higher predicate.

The RG framework postulates a series of levels of representation, called strata. Each stratum contains a

predicate and a series of grammatical relations (GRs) associated with it which are labeled 1 (subject), 2 (direct object), 3 (indirect object), obl (oblique, which includes a variety of non-nuclear GRs, such as benefactives, malefactives, etc.) and chomeur (demoted argument). Each argument in each clause might be associated with different GRs at different strata. The identity of the argument is preserved by an arch, which connects the different strata. An arch (argument) sometimes can be complex, such as an embedded clause, or a possessive argument containing an H (head, or possessed) and a Poss (possessor).

GRs are primitives in RG. Different GRs at different strata can be identified by a series of tests, some universal, some language-specific. When the same argument passes the tests of different GRs, then a difference from stratum to stratum is proposed to account for this multiplicity.

In many languages, a nominal Poss, which is semantically a possessor with respect to another nominal H, does not appear in the surface as a Poss, but rather in a GR related to the same predicate as H. This process is called Possessor Ascension (PA) in the RG tradition, and Possessor Raising (PR) more generally.

One example of Possessor Ascension comes from Kinyarwanda (Bickford 1988):

- (4) a. umugóre u-a-vun-nye ukúboko k'ú úmwáana
 woman 3sS-Pst-break-Asp arm of child
- b. umugóre u-a-vun-nye úmwáana ukúboko
 woman 3sS-Pst-break-Asp child arm

'The woman broke the child's arm.'

(4)a is an instance of a possessive construction without raising, where the possessor stays in the direct object, introduced by a preposition. In (4)b, the possessor has raised to the position normally occupied by indirect objects in Kinyarwanda, where the two objects appear unmarked, in the order verb-indirect object-direct object. The two sentences have the same meaning so they are understood to be related through a process of Possessor ascension.

Thus, in the first stratum, where thematic relations are established, the possessor is part of the same arch as the possessed, an arch which splits into two relations, H and Poss:

(5)	1	P	2[H	Poss]
	umugóre	u-a-vun-nye	ukúboko	úmwáana
	woman	broke	arm	child

If the sentence is spelled out as in this stratum, (4)a obtains, and the possessor is introduced by the preposition *k'ú* 'of'. An alternative is to apply Possessor Ascension at the next stratum, raising the Poss to the 3-GR:

(6)	1	P	2[H	Poss]
	1	P	2	3
	umugóre	u-a-vun-nye	ukúboko	úmwáana
	woman	broke	arm	child

When this rule applies, the language will actually rearrange the order of constituents, so that the raised Poss, now a 3, appears adjacent to the verb, yielding the order in (4)b. Given that RG does not consider word order to be a primitive in defining GRs, it is assumed that an independent linearization rule takes care of the final linear order of constituents in the sentence.

Initially, RG analyses assumed that PA followed the

Relational Succession Law (RSL), formulated as in (7) (Perlmutter and Postal 1983:35).

(7) Relational Succession Law

An ascendeo assumes within the clause into which it ascends the GR of the host out of which it ascends.

The meaning of this Law is that an NP which raises out of a 2 can only become a 2, and one that raises out of a 1 can only become a 1. Alternatively, it also predicts that the clause out of which an NP raises to subject must be a subject clause, and the clause out of which an NP raises to object must be an object clause. Understood in the latter way, the RSL helps postulate the original GR of the clause.

Early analyses of PA tended to observe the RSL, including those of Cebuano (Bell 1983), Malagasy (Keenan 1972, Perlmutter and Postal 1983), Sierra Popoluca (Marlett 1986), or Southern Tiwa (Allen et al. 1990). However, later studies found a number of examples of violations of the RSL in PA constructions. Especially common are those that raise the possessor out of a 2 to become a 3, including the aforementioned Kinyarwanda, as well as Tzotzil (Aissen 1987, 1990), Albanian (Hubbard 1985), Choctaw (Davies 1984, 1986), or Georgian (Harris 1981). Eventually, RG syntacticians stopped regarding the RSL as a universal principle.

The framework that I will be using in this dissertation is not Relational Grammar, thus some of the details of the analysis will have to be revised. GRs are not understood as primitives in the GB/Minimalist tradition. They are instead understood as positions in the syntactic structure, where certain lexical features enter into relations with other features of different

lexical items.

Thus, instead of positing a language-specific grammatical rule that raises a possessor to a certain GR, I will propose that the possessor has a certain feature that needs to be checked outside the constituent where it is generated as a possessor. The effects are the same, but the burden is placed on the lexical/morphological makeup of lexical items, rather than placing it in the grammar itself. Once the features of the lexical items enter a syntactic derivation of a sentence, they must be properly checked in order to produce a grammatical output at the interface. The checking procedures are general and in many cases very well understood.

2.2 The Possessor that Ran Away from Home

In this section I will discuss the analysis of Hungarian possessives by Szabolcsi (1983, 1994). This analysis was one of the first and most original applications of possessor raising in the Government and binding (GB) framework, and has spurred a number of proposals based on its ideas.

Szabolcsi (1983) notes that possessives in Hungarian can appear in several positions.

- (8) a. az én vendég-e-m
the I-NOM guest-poss-1s
'my guest'
- b. én-ek-emaz a vendég-e-m
I-dat-1s the guest-poss-1s
'my guest'

In both instances, the possessed noun shows person and number agreement with the possessor. The differences are the position and the Case of the possessor. In (8)a,

the possessor appears between the determiner and the possessed, and is marked with nominative Case. In (8)b, the possessor appears in front of the determiner, and bears dative Case.

Szabolcsi thus concludes that the two positions and their Cases must be related to one another. She thus proposes the following structure:

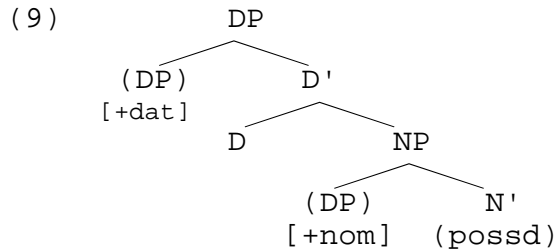

The lower position, which has come to be analyzed as [Spec,NP], is where nominative Case is assigned. Most likely this is not the position where the possessor receives its thematic role, but rather it moves there for Case reasons.

The higher position, which is usually identified as [Spec,DP] (following Abney 1987 and others), is where dative Case appears. Szabolcsi (1994) discusses the mixed nature of the position. On the one hand, it shows the properties of an A-position, because it appears that a Case is checked/assigned there. On the other hand, it should be an A'-position for two main reasons. First, she assumes that the possessor arrives at [Spec,DP] after passing through [Spec,NP], where agreement with the possessed is established. If the possessor is already Case-marked at [Spec,NP], then it would be anti-economical to have it move to a second Case-position. Second, [Spec,DP] shows some properties of A'-positions. The dative possessor appears able to move to A'-positions

only, which is consistent with the requirement against improper movement. If [Spec,DP] were an A-position, the possessor should be able to move to higher A-positions without violating the requirement. Also, if an embedded possessor is raised to [Spec,DP], then the higher possessor must also move to [Spec,DP], in a sort of clausal pied-piping.

Interestingly, a possessor in Hungarian may be found outside the boundaries of the DP, but crucially it has to be marked dative, as in (10)a, and never nominative, as the ungrammaticality of (10)b shows.

(10) a. Péter-nek Mari látta a kalap-já
P-dat M saw the hat-poss.3s
'As for Peter, Mary saw his hat.'

b. *Péter Mari látta a kalap-já

Szabolcsi analyzes this fact by making [Spec,DP] be an escape hatch, where possessors must stop on their way out of the DP, much in the way [Spec,CP] works in successive cyclic movement.

It must be noted, however, that this movement is not the kind of possessor raising that we saw in the previous section, which amounts to movement to an A-position. If [Spec,DP] is an A'-position, as Szabolcsi seems to imply, then possessor raising to an A-position would result in an improper movement violation. It is fitting, then, that possessor extraction in Hungarian is to A'-positions only.

The originality of Szabolcsi's analysis is that she compares the internal structure of the DP to that of the clause, or CP. Thus, she proposes the existence of functional projections inside the DP, where features such as agreement and Case can be checked. She also takes the

analogy to the end, making a distinction between A and A'-positions inside the DP, and forcing extraction to go through the peripheral A'-positions on its way out of the DP.

As is to be expected, the analysis has caused an explosion of functional projections of different nature in the DP, motivated by word order facts and by the generalization that all inflectional morphology should be represented as separate heads in the syntax (Baker 1985, 1988). In this dissertation, I will make use of functional projections inside the DP, although I will not assume all the projections proposed in the literature. I will in fact argue against the existence of some of them.

2.3 Auxiliary Selection and Possession

In this section I will discuss several analyses where the possessive construction is related to uses of the copula *be* and its equivalents in other languages.

2.3.1 Locatives, Existentials and Possessives

Freeze (1992) shows examples from several languages where locative, existential and possessive constructions show very similar structures. An example is Russian:

- (11) a. na stole byla kniga
on table-LOC was book-NOM
'There is a book on the table.'
- b. u menja byla sestra.
at my-GEN was sister
'I had a sister'

As we can see, the possessive construction in (11)b has a parallel structure to that of the locative (11)a,

including the form of the copula. Freeze assumes a common initial structure for both sentences, where there is no lexical verb. The copula is inserted directly under INFL, as a place holder for the inflection. The INFL head directly selects a PP which has two arguments. The theme is the [Spec,PP], whereas the location/possessor is the complement of the preposition:

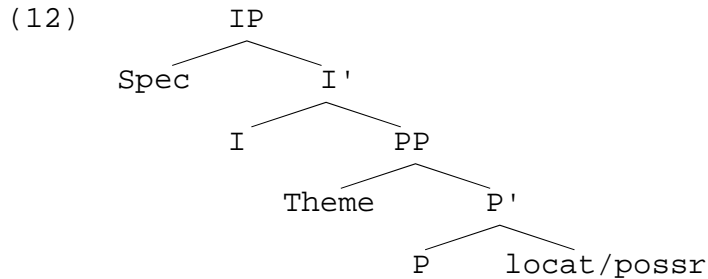

From this initial structure, Freeze assumes that either argument can move into the [Spec,IP] subject position. When the Theme moves, we get the typical locative sentence. The other alternative is to have the intermediate projection P' move to the subject position, yielding the order in the examples in (11).

According to Freeze, the only difference between the locative existential and the possessive construction is that the possessive locative/possessor is usually human, or is related to the theme by an inalienable relation.

A different set of languages have different copulas in locative/existential and possessive sentences, usually realized as the typical *be/have* alternation. Freeze analyzes the alternation as the result of the incorporation of the locative preposition into the copula in INFL.

There are two pieces of evidence for this analysis: first, in these languages, the preposition does not move along with the possessor, which appears in the usual

subject Case for the language in question.

Second, the preposition incorporation is sometimes reflected directly by word order, as in the following Spanish example:

- (13) a. El niño tiene hambre.
 the boy has hunger
- b. El niño está con hambre.
 the boy is with hunger

'The boy is hungry.'

In both (13)a and (13)b, the possessor has moved to the subject position. In (13)a, the incorporation of the preposition is not immediately transparent, but surfaces in the form of *tener* 'have'. In (13)b, we see the preposition appearing in front of the theme, which means that it has moved past its own Spec into the verb, as in (14).

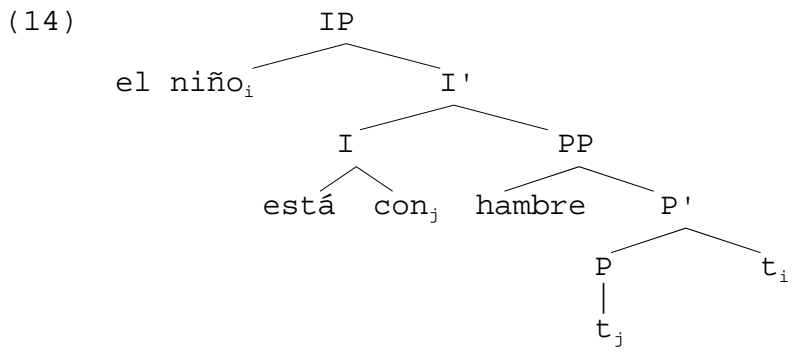

The impossibility of pied-piping the preposition in the case of a question shows that the preposition and the theme in (13)b do not form a constituent:

- (15) *Con qué está el niño
 with what is the boy

Freeze's analysis is a different take on possessor raising from that of Szabolcsi (1994). First, Freeze considers possession to be a subcase of location. This

leads him to assume that the possessor and the possessed are not part of the same DP, but of a PP headed by a transitive preposition which mediates the relation between two independent DPs, as in any instance of possession.

Another interesting contribution by Freeze is the analysis of *have* as an instance of *be* with an incorporated preposition. The parallel between the two constructions has been exploited repeatedly in the subsequent literature.¹ In this dissertation, I will follow part of Freeze's analysis, especially in the form taken by later interpretations of the parallel between location and possession.

2.3.2 Possessive Auxiliary Derivation

Kayne (1993) recovers the spirit of Szabolcsi's (1983, 1994) analysis, and tries to apply it initially to possessive constructions in English, and eventually to a set of Romance dialects which differ in the form of their auxiliary and possessive verb.

Kayne takes on the task of analyzing three possessive constructions in English:

- (16) a. John's three sisters.
b. Three sisters of John's.
c. John has three sisters.

Recall from Szabolcsi that possessed nouns in

¹ The idea is already presented in Benveniste (1971). See also, among others, Kayne (1993), Hornstein et al. (1994), Español-Echevarría (1995), Kempchinsky (1995), Uriagereka (1996), Castillo (1998a, 1998b).

Hungarian show agreement with their possessors. Kayne proposes that there is a functional projection called AgrP, where the possessive relation is thematically established. In some instances in English, Agr is realized as the possessive marker 's. AgrP is dominated by DP, whose head D is unrealized in English when definite, as in (17).

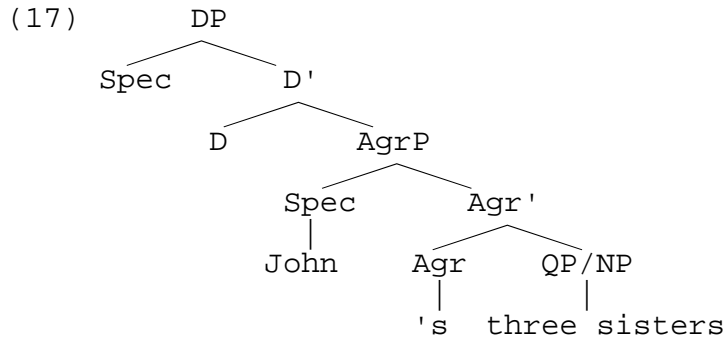

In English, when the possessive DP is indefinite, the possessed must move to [Spec,DP], and D is realized as the preposition *of*, as in (18).

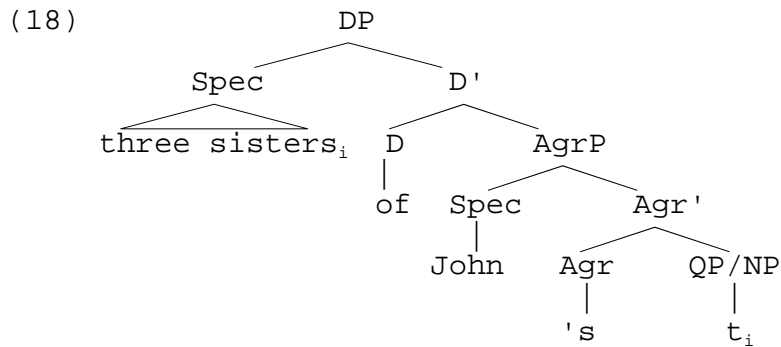

The spell-out of D as a preposition in English underscores, in Kayne's opinion, the fact that the position in question is ambiguously defined somewhere between a determiner and a preposition. Here, he also takes on Freeze's (1992) analysis and makes this D/P head be the abstract preposition that incorporates into the copula *be* to form the possessive verb *have*. Thus, Kayne

distinguishes between *BE*, the copula as it comes from the lexicon, and *be*, its spell-out when there is no incorporation of D/P.

Also, Kayne recovers the original analysis by Szabolcsi, by making the possessor be part of the same DP as the possessed, instead of having them be separate DPs, as Freeze suggested. Kayne concedes to Freeze's proposal that the whole constituent is a PP, by maintaining the ambiguity of the head between D and P.

Kayne now reconciles the analyses by Freeze and Szabolcsi. Recall that Szabolcsi postulated that [Spec,DP] is an A'-position, akin to [Spec,CP]. Kayne assumes that the incorporation of D/P into BE is precisely triggered by the need to turn [Spec,DP] into an A-position. This will allow a possessor to stop at that position on its way out of the DP, and still move further to other A-positions, such as subject.

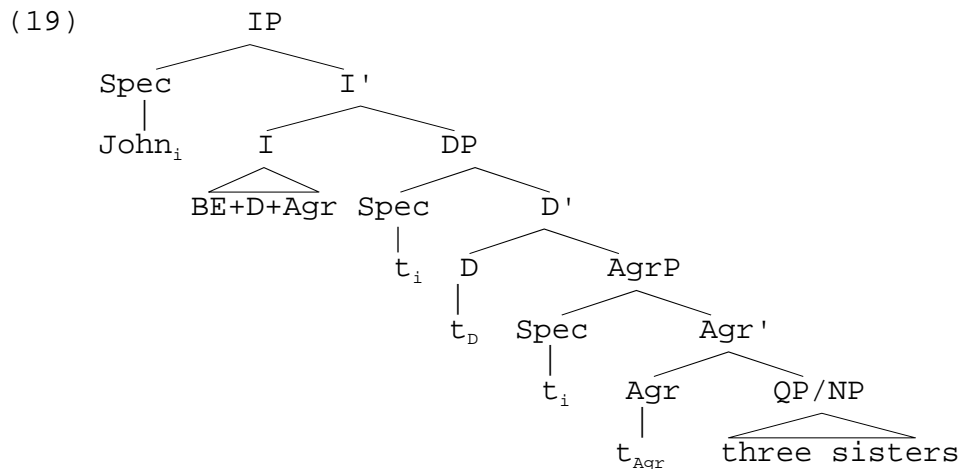

Kayne goes on to extend Freeze's analysis of the possessive *be/have* alternation to the perfective auxiliary alternation between the same verbs, observed in many languages. Ultimately, the result of the proposal is that all instances of *be* and *have* cross-linguistically

are in fact spell-outs of the same abstract copula *BE*.

2.3.3 Integrals

Hornstein et al. (1994) find yet another type of construction related to these analyses. In a new twist on the possessive/locative similarity, they point out that some existential sentences, such as (20) are ambiguous between what they call an integral, inalienable or part-whole, interpretation (II) (21)a, and a standard, alienable or locative interpretation (SI) (21)b.

(20) There is a Ford T engine in my Saab.

(21) a. My Saab has a Ford T engine.

b. (Located) in my Saab is a Ford T Engine.

Hornstein et al. accept the basics of the analysis put forth by Szabolcsi (1983, 1994) and Kayne (1993), but they propose that the difference between the two readings in (21)a and (21)b resides in the initial structures. In the II, the whole/possessor is the specifier of AgrP and the part/possessed is the complement of Agr:

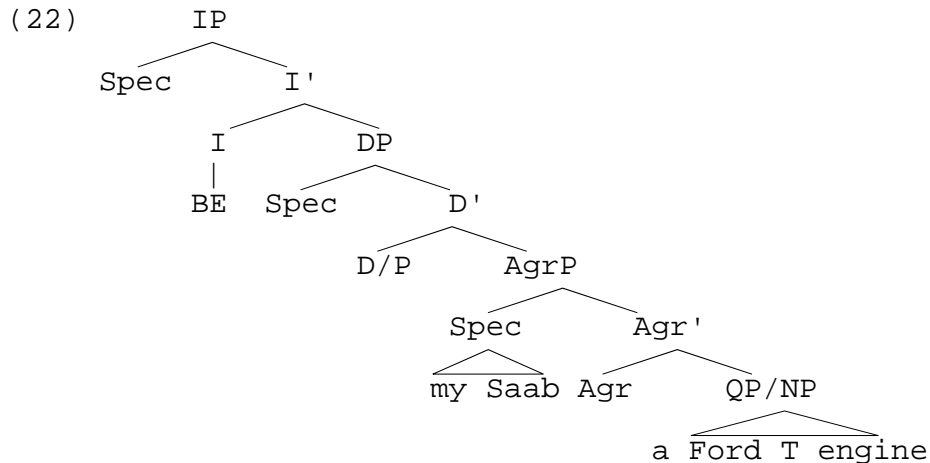

On the other hand, the SI has the location as the

complement of the preposition, as Freeze (1992) originally suggested, and the theme in [Spec,PP]:

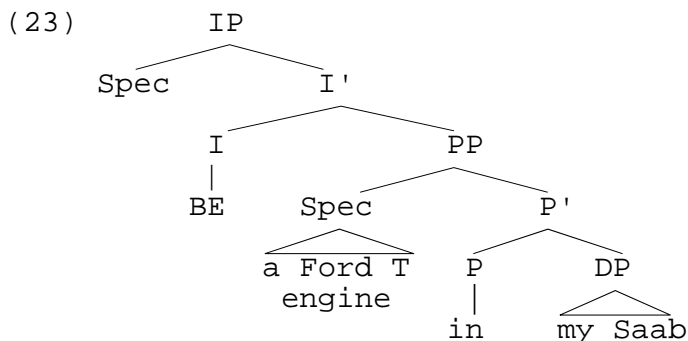

A series of contrasts between II and SI are explained away by this proposal. First, only SIs have *be*-paraphrases such as the ones in (24).

(24) a. A Ford T engine is in my Saab.

b. *Ten provinces are in Canada.

(24)a only has an SI interpretation, and (24)b, where the sentence is only true with an II reading, is simply ungrammatical. In the II structure, these paraphrases include movement from [Spec,DP] to [Spec,IP], without D/P incorporating into BE (thus its *be* spell-out). Following Kayne (1993), this is an instance of improper A' to A movement because only the incorporation of D/P turns [Spec,DP] into an A-position. The issue does not arise in the SI, because the sentence is a simple locative, not a true possessive of the kind that Kayne discusses.

Two other contrasts are derived from the fact that in the II the preposition and the whole do not form a constituent. First, they cannot move together on wh-movement. Therefore, (25) can only have an SI reading.

(25) On which elephant do you believe that there is a big trunk?

Because (25) can only be an alienable construction, the trunk in question cannot be the part of the elephant's body, but only a big suitcase that the elephant is carrying.

Similarly, PP-modifying adverbs can only be found in the SI sentences and not in the II, where the linear sequence P-NP is never really a PP.

(26) There is a Ford T engine right in my Saab.

Once again, (26) cannot be an II, because only in the SI the PP is a constituent.²

Finally, Hornstein et al. extend their analysis in an attempt to cover the inalienable relations discussed by Vergnaud and Zubizarreta (1987). These are sentences in French in which an apparent indirect object is interpreted as the possessor of its direct object:

(27) a. Le médecin a radiographié l'estomac aux
the doctor has X-rayed the-stomach to-the
enfants.
children

'The doctor X-rayed the children's stomachs.'

b. Le médecin leur a radiographié l'estomac.
the doctor to-them has X-rayed the-stomach

'The doctor X-rayed their stomachs.'

For Hornstein et al., this is simply one more instance of their II structure, where the apparent indirect object is the whole and the direct object is the part. Thus, (28) will be the structure for the full-DP possessor version (27)a.

² Aschan (1995) and Muromatsu (1998) find similar contrasts in Finnish and Japanese, respectively. In Japanese, SIs show that the postposition attached to the location forms a constituent with it, but the postposition in IIs is not a true postposition.

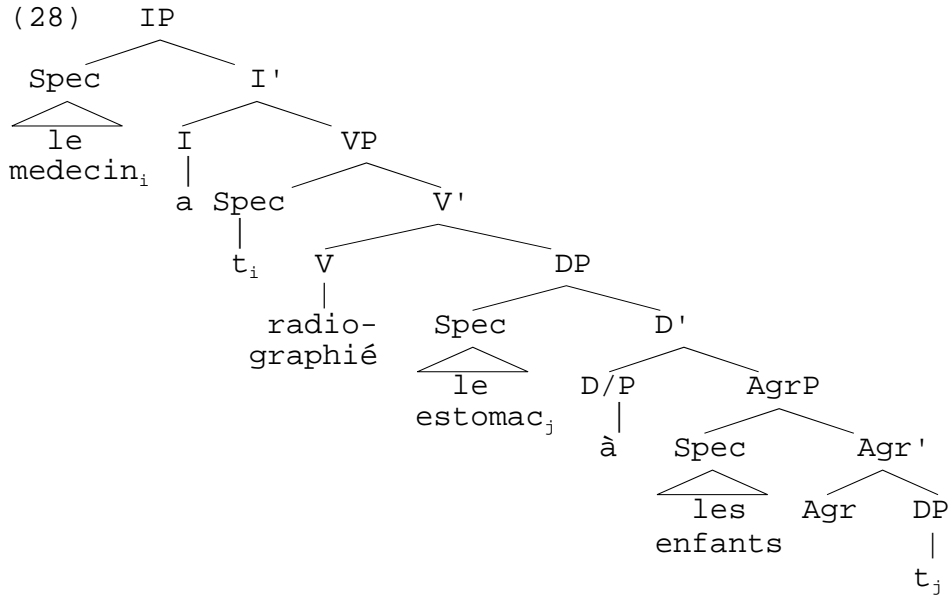

In (28), the possessor/whole stays in its base position, and the preposition *à* (spelled-out as *aux* when contracted with a plural article) is inserted.

The clitic version (27)b will have the structure in (29).

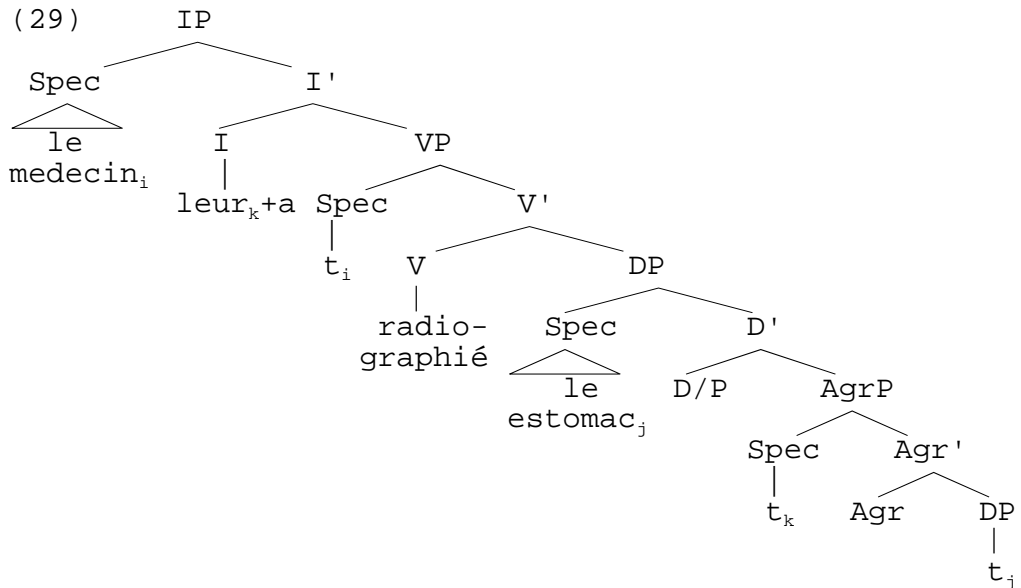

In (29), the possessor is realized as a clitic, and moves in front of the verb, making the insertion of the preposition superfluous.

Uriagereka (1996) points out that even though many different relations between nouns can be considered possessive, not all of them can. In order to explore the nature of these relationships, he proposes an abstract semantic relation R^3 that underlies possessive constructions.

Uriagereka further rejects the idea that any noun may be inherently relational,⁴ based on the fact that any noun can be in an R-relation with respect to any other noun, given sufficient context, and provided that the relation in question falls within the semantic confines of R.

Next, Uriagereka points out a paradigm that shows certain syntactic restrictions on the derivations that a possessive construction allows:

(30) a. The poor neighborhoods of the city.

b. The city's poor neighborhoods.

(31) a. A city of poor neighborhoods.

b. *The/a poor neighborhoods' city.

First, he notes that all the examples in (30) and (31) sport the same instance of R, a part-whole relation between a city and its neighborhoods. He also points out that the reference of the different DPs varies. The referent in (30) is the neighborhoods, whereas the one in

³ R is already introduced in Hornstein et al. (1994), and presented as loosely based in the relation C that Burge 1975 used to describe the composition relation between things and the matter they are made of.

⁴ A view defended by Keenan (1987), Barker (1995), among others. In Chapter 5, I will make the weaker claim that a very restricted set of terms, specifically kinship terms, are relational.

(31) is the city. This rules out the reference of the whole *city* as the reason why (31)b is ungrammatical.

In fact, when considering the Spanish facts, we discover that the reason for the ungrammaticality of (31)b is the fact that the part cannot appear preceding the whole in a possessive construction.⁵

(32) a. Los barrios pobres de la ciudad.
the neighborhoods poor of the city
'The city's poor neighborhoods.'

b. Sus barrios pobres.
its neighborhoods poor
'Its (the city's) poor neighborhoods.'

(33) a. Una ciudad de barrios pobres.
a city of neighborhoods poor
'A city of poor neighborhoods.'

b. *Su ciudad
its city
'Its (the poor neighborhoods') city.'⁶

Uriagereka uses the Szabolcsi/Kayne structure, but takes advantage of a point neither one ever left completely clear, which is whether the Agr-projection is the place where the thematic possessive relation is established, or a position reached through movement from a lower thematic position.⁷ For him, [Spec,Agr] checks a

⁵ In Spanish, only pronouns can appear as DP-internal prenominal possessors.

⁶ (33)b is grammatical under many different interpretations, but crucially not under the intended one, where the possessive pronoun stands for the part of a part-whole relation.

⁷ In fact, Szabolcsi (1994) has a structure in which she assumes a lower PossP projection, where a Poss-head assigns the possessive theta-roles. The reason why she does things this way is, curiously, very similar to those used by Uriagereka (1996). Szabolcsi does not see a

referential formal feature [+r], which can be borne by either member of the R-relation. Therefore, R must be established somewhere else. Uriagereka proposes that it is the result of a headless small clause, which is selected by Agr.

A second semantic feature, called [+c], is housed in D, and checked in its Spec. This feature corresponds to the contextual confinement of the reference for the whole expression.⁸ Thus, the complete structure is as in (34).

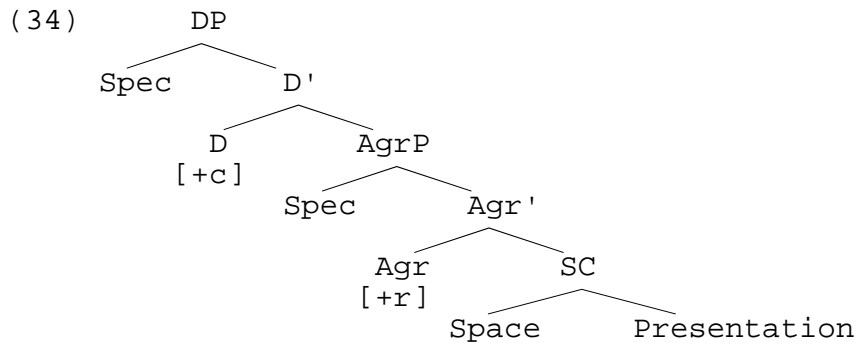

Now, we can follow the different derivations of the examples in (30) and (31), to find out why all of them except (31)d are grammatical. (30)a and (31)a are not problematic. Assuming that the preposition is the spell-out of the Agr-head, then in these two examples only one of the two terms of the SC actually leaves it. (30)a has the structure in (35).

reason why a noun such as *hat* should inherently have a possessor theta role in its lexical entry. Kempchinsky (1996) and Castillo (1998a) make use of this PossP projection in their analyses of the possessive verb *tener* in Spanish.

⁸ See Higginbotham (1988).

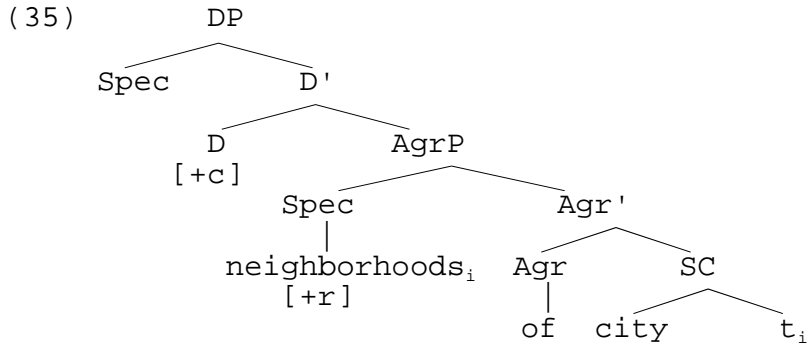

On the other hand, (31)a is as in (36).

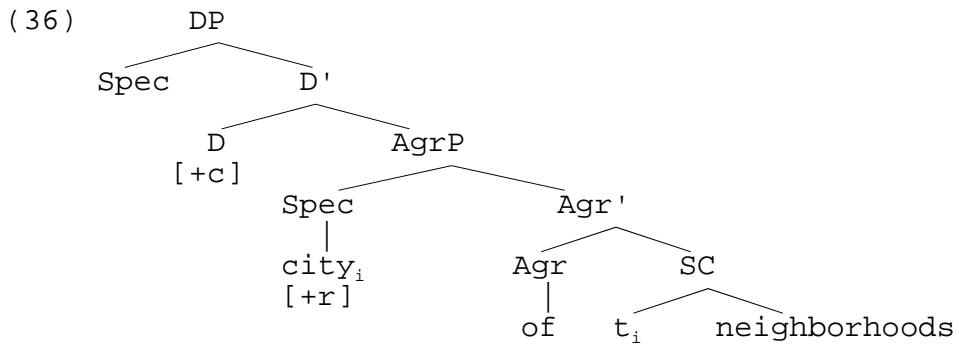

The syntactic issue appears when both terms leave the SC, as hinted at by the lack of preposition in (30)b and (31)b. In the former, the movements of the two nominals interleave, thus yielding a well-formed derivation, as seen in (37).

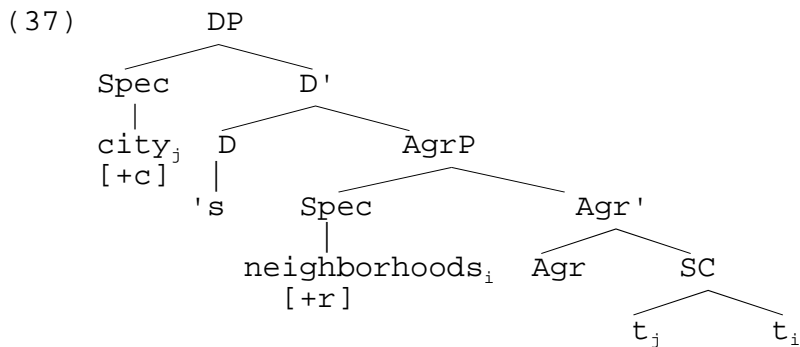

In (31)b, the movement of *neighborhoods* nests that of *city*, producing a Minimal Link Condition violation, as shown in (38).

(38)

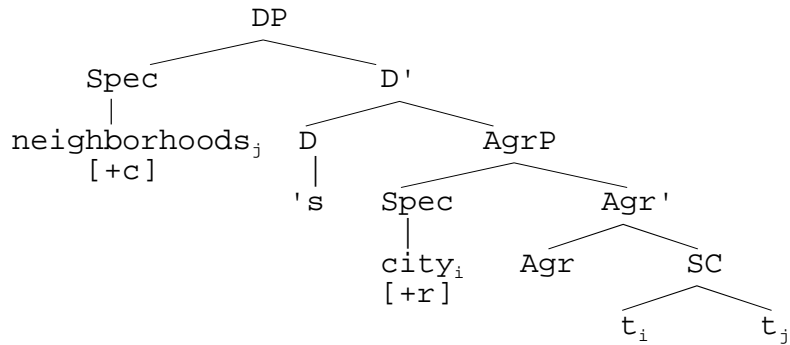

Such an analysis explains the contrasts seen in (30) and (31), and their Spanish equivalents (32) and (33), not by imposing semantic constraints on the types of possessive constructions that can be created, but by invoking well-known, independently motivated syntactic constraints on derivations.⁹

Uriagereka goes on to analyze variations on this theme which show the paradigm already seen in Freeze (1992) and Kayne (1993) that involves *have/be+P*. The main ideas are not very different from the two previous analyses, even though certain details slightly differ. I will not discuss the details here, but I want to concentrate on two major points of Uriagereka's analysis before I go on to the next section.

The analysis offers some pleasant features that I will take advantage of in this dissertation. First, a single thematic configuration can account for grammatical and ungrammatical sentences, where the same terms appear in the same part/whole relation. This is highly desirable.

In addition, the relativization of reference to a feature checked by movement will be crucial to some parts

⁹ See Chomsky (1995:ch. 3-4), where we find two different versions of the MLC.

of my dissertation. In subsequent chapters, I propose additional examples where the data requires a dissociation between thematic structure and reference.

Furthermore, [Spec,AgrP] is the position where the agreement features of the whole DP are checked. Consider in this sense the agreements triggered by the grammatical examples pointed out in Uriagereka (1996):

(39) a. The neighborhoods of the city are poor.

b. The city's neighborhoods are poor.

(40) a. Los barrios de la ciudad son pobres.
the neighborhoods of the city are poor
'The city's neighborhoods are poor.'

b. Sus barrios son pobres.
its neighborhoods are poor
'Its (the city's) neighborhoods are poor.'

(41) A city of neighborhoods is always poor.

(42) Una ciudad de barrios es siempre pobre.
a city of neighborhoods is always poor
'A city of neighborhoods is always poor.'

When the referent is the plural *neighborhoods*, as in the English (39) and their Spanish equivalents (40), the DP shows plural agreement with the verb and, in the Spanish example, even with the post-verbal predicative adjective. On the other hand, the examples (41) and (42), where the reference feature is checked by the singular *city*, the agreement with both the verb and the adjective (if applicable) is singular.

This means that the position of [Spec,AgrP] not only checks referential, but also agreement features for the DP as a whole. The fact that this position is separated from the place where the thematic relation R is established means a relativization of properties that had

traditionally been thought of as rigidly belonging to the head of an NP. Now that agreement and reference can be altered through the syntactic derivation, certain predictions are made with respect to the traditional properties of heads, which I will prove to be true in Chapter 2.

2.4 Warps

This section will introduce the specific categorial theory assumed in this dissertation. The theory stems from the work done by Uriagereka (1995), Muromatsu (1998) and Mori (1997), and later on assumed in one form or another by a number of works.¹⁰

The theory is based on a modular conception of categories, which are built along a dimensional hierarchy. Each category thus comprises, implies, and is more complex than, the one that immediately underlies it. The analogy that Uriagereka (1995) proposes is that of topological dimensions. A line is the most basic space, a one-dimension domain. A plane, which is a two-dimension space, comprises an infinite set of lines, and has all the properties of lines, plus others. A three-dimensional space includes an infinite number of planes, and adds new properties of its own, and so on.

Grammatical categories are assumed to work in this way. Mori (1997) and Atutxa (2000) have studied the verbal paradigm, and the reader is referred to their works. In this dissertation, I will limit myself to the

¹⁰ Including, not in an exhaustive mode, López Díaz and Quintana (1996), Castillo (1997, 1998b, 1999), Etxepare (1997), Quintana (1998), Bleam (1999), Atutxa (2000).

nominal categories, but in both paradigms we find a series of categories which, as predicted by the model, behave syntactically according to a complexity hierarchy. It is important to understand that, since we assume that the difference between these categories is purely syntactic, any conceptual or semantic difference in complexity should correlate with a parallel syntactic complexity in the same direction. The purpose of this dissertation is to find, describe and analyze the mechanisms that derive a more complex category from a more basic one.

Sticking to the nominal categories then, I will follow Muromatsu (1998) in assuming three basic categories, which are ordered in terms of their internal complexity, both conceptual and syntactic:

- | | |
|------------------------------------|-----------------------------|
| (43) a. 1D: +degree -measure -form | Predicative
use of nouns |
| b. 2D: +degree +measure -form. | Concrete mass
term |
| c. 3D: +degree +measure +form. | Count noun |

(43)a is the simplest of them all, both conceptually and syntactically. Conceptually, it is a simple predicate, similar to an adjective. Syntactically, it typically appears as a bare noun, or accompanied by adjectival degree modifiers, such as *more*, *very*, etc. We will call such a use, a 1-D noun.

(44) This soup tastes like chicken.

(43)b is a mass term, which we will call 2-D, assuming that it already has a more complex ontology. Conceptually, it can have reference, and thus it can appear as the argument of a predicate, rather than just

as a predicate. Syntactically, it allows a number of quantifiers, measure phrases and other constructions which were not possible with a 1-D:

(45) There is some/a lot of/much chicken in this soup.

The difference between 1D and 2D, according to Muromatsu, is the presence of a measure, which acts as a type-lifting predicate, technically called a warp, from 1D to 2D. The measure is the predicate of an integral small clause that lifts the type of the noun:

(46)

```

      SC(2D)
     /    \
    1D     measure
  
```

Finally, 3D nouns, typified in (43)c, are the most complex of the three. They are not only referential, but also bounded and thus individuated, which allows for a number of conceptual characteristics, such as being susceptible of being counted, and having parts.

Syntactically, they allow numerals, a wider array of determiners, and the interaction with telic predicates.

(47) There is a (whole) chicken in this soup.

The warp that lifts a 2D type into a 3D is a classifier, similar to the particles found in languages like Japanese and Chinese. The classifier allows the content of the noun to be individuated, and counted:

(48)

```

      SC(3D)
     /    \
    SC(2D)  classifier
   /    \
  1D     measure
  
```

The dynamicity of this system allows Muromatsu to handle the changes in character that nouns can undergo in different syntactic contexts, such as the uses of *chicken* in (44), (45) y (47).

Also, notice that there is a unidirectional entailment relation in the examples above from the higher to the lower dimensions. (47) entails (45), given that if the soup has a chicken in it, then it has some chicken meat in it. However, the contrary entailment does not hold. Similarly, if there are some loose parts of chicken meat in the soup, that does not entail that there is a whole chicken in it, which we can treat as a countable unit.

Leaving aside what might be called *canonical readings*, which all nouns certainly exhibit,¹¹ it would be hard to account for data like those in (44), (45) and (47) if all nouns came with a specified dimension in the lexicon. Given that the same noun can be used at different dimensions, we would have to propose multiple lexical entries for each noun. In contrast, Muromatsu's system derives dimensions by way of a trivial syntactic mechanism. And crucially for us here, her system also allows us a straightforward analysis of the asymmetries found in content-container readings.

Chapters 2 and 3 of this dissertation will deal with

¹¹ In the case of *chicken*, it is not very clear whether the mass term, understood as food, or the count noun, ambiguous between food and the living animal, is more salient. Examples such as *beef/cow*, or the Spanish *pescado/pez* ('fish'), raise the issue that some nouns, *chicken* among them, may have two homonymous lexical entries. But the variations go well beyond the realm of

issues of categorization of nouns, and the nature of the predicates that serve as type-lifters for them. The mentioned chapters will provide evidence that there is a difference in complexity between the uses of nouns described in Muromatsu (1998), and will also provide some insight into what the realization of the classifier is in different languages.

3 Outline of the Dissertation

The chapters that follow are organized as follows.

Chapter 2 presents some facts about extraction out of DPs, and proposes that extraction has some correlates with verb selection. Specifically, Container-Content DPs such as *a bottle of beer* are assumed to be ambiguous between a Content reading, where the verb (*drink*) selects for the content, and a Container reading, where the verb (*break*) selects the container. Extraction is argued to be possible out of Content readings only. The analysis implies that while Content readings are understood as mass terms to which a measure has been applied, Container readings must be understood as count nouns of higher complexity. Because the whole expression *bottle of beer* is the subject of a small clause in the Container reading, it becomes an opaque domain for extraction. The chapter also argues that selectional restrictions and agreement cannot be properties of the same lexical item in these DPs, and thus the traditional concept of head should be revised.

Chapter 3 presents some data from shifts in

the food vs. animal distinction, suggesting that the

interpretation from count nouns to mass terms. Specifically, the chapter argues that, in some constructions, a noun that is commonly interpreted as count lacks the sufficient syntactic structure to be interpreted as such. It will be argued that only count uses of nouns can appear in integral relations with parts, and those uses depend on the presence of Number. Number, in languages that have this morphological feature, will play the role that classifiers take on in languages without Number, mainly to be the warp from 2D to 3D. A consequence of the analysis is that mass uses of nouns must lack Number, a prediction which will be shown to be true.

Chapter 4 discusses Possessor Raising in Spanish. There are two Cases that a raised possessor can check in Spanish, namely nominative and dative. The former is restricted to so-called verbs of internal movement, and to animate possessors in relation to their body parts. It will be argued that possessor raising to nominative shows the same parallel with clitic doubling previously noticed for possessor raising to dative. The latter part of the chapter discusses the way that different kinds of possessive relations interact with possessor raising. Special attention will be devoted to the issue of the argument structure of nouns, and it will be argued that only a few nouns have a thematic position in their lexical entry. Finally, it will be shown that inalienable relations, such as part-whole and kinship are more restricted in their syntactic realizations than more alienable ones.

lexical pairs may be the exception.

Chapter 5 discusses a universal typology of languages with regard to Possessor Raising. It will be argued that languages with this construction need to have a structural Case to assign to the raised possessor. Causatives and ditransitives will be used as evidence that the Case is indeed available and structural. Languages will be divided into four types: Type 1 lacks Possessor raising; Type 2 has accusative possessors after the possessee has incorporated into the verb; Type 3 has multiple accusative; and Type 4 has dative possessors. Each type is analyzed assuming common initial structures, and differences are tied to the morphological properties of the functional heads in the extended projection of the verb.

Finally, Chapter 6 includes the conclusions and some suggestions for further research in the areas covered by this dissertation.

CHAPTER 2
THE SYNTAX OF CONTAINER-CONTENT RELATIONS

This chapter explores the structure of Determiner Phrases that encode container-content relations. The goal is to find an analysis that accounts for a variety of phenomena around this kind of DP, which touch on such diverse issues as thematic relations, reference, raising, wh-extraction and others. In the process, I will point out a correlation shown by Catell (1976) between the internal structure of the DP and its permeability to extraction, both through A- and A'-movement. I will also claim that the traditional concept of *head* of a DP cannot account for this correlation, and that agreement and selectional restrictions must be determined by different positions within the DP. I will use data mostly from Spanish, but a good part of the analysis works for English in much the same way.

I will follow the general assumptions of the Minimalist Program, as outlined in Chomsky (1995). Sentences are understood as a pair of representations, PF and LF, which are interpreted at two interfaces, the Acoustic-Perceptual interface (A-P) and the conceptual-intentional interface (C-I) respectively. The implementation of these interfaces may be done by means of levels of representation, in the sense of Chomsky (1955) or by components, as proposed by Epstein et al. (1998), or Uriagereka (1999a). The computational system C_{HL} takes lexical items from a previously selected numeration N and arranges them into phrase markers by the operations Merge and Move (not necessarily understood as primitive operations; see Nunes 1995, Collins 1997,

Kitahara 1997 for some discussion). A derivation must exhaust the numeration and converge at both LF and PF; otherwise it crashes.

For the purposes of this chapter, I will take selectional restrictions to be relations between semantic features, determined at the point of merge, in a way that may invoke a D-structure component, and may possibly be interpreted after LF. Such semantic relations should play no role in the syntactic derivations. Sentences that violate selectional restrictions but are otherwise well-formed with regard to the derivation and manipulation of their formal features will be considered as convergent but uninterpretable.

The chapter is organized as follows. Section 1 shows the ambiguity inherent in container-content DPs and how traditional accounts are unable to handle it. Section 2 presents the theoretical framework that will allow us to derive the ambiguity in a principled way. Section 3 will show how to analyze the wh-movement out of container-content DPs in ways that are consistent with current minimalist assumptions. Section 4 will sketch an extension of the analysis to picture-NPs and other more abstract cases of container-content relations.

1 Container-Content DPs

1.1 The Concept of Head

Selkirk (1977) notices that a DP which denotes a container-content relation can display the structural ambiguity illustrated in (1).

- (1) a. She drank a bottle of that good wine.

b. She broke a bottle of that good wine.

In (1)a, the object must satisfy the selectional requirements of the verb *drink*, such as the fact that its object must be liquid. In (1)b, on the other hand, the verb *break* requires a solid object. Between the two candidates inside the object DP, it is obvious that the content *beer* must satisfy the selection in (1)a and the container *bottle* must be the selected noun in (1)b.

The intuition is directly confirmed by the data in (2):

(2) a. I drink beer every day.

b. I break a bottle every day.

If we leave out one of the two elements of the DP of concern here, it is obvious that *beer* can be the object of *drink* and *bottle* can be the object of *break* and no other combination is possible.

Because the selectional requirements of the verb in (1)a are satisfied by the content of the DP referent, I will call this interpretation the Content reading. In turn, the interpretation in (1)b where selection is satisfied by the container of the DP referent will be called Container reading.

Selkirk proposes two different structures for the two readings, encoded lexically as two phrases with different heads:

(3) Content Reading

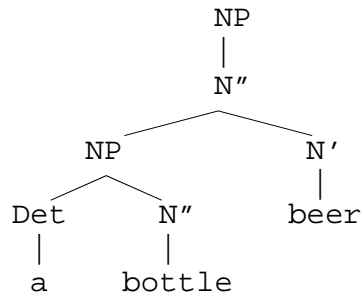

(4) Container Reading

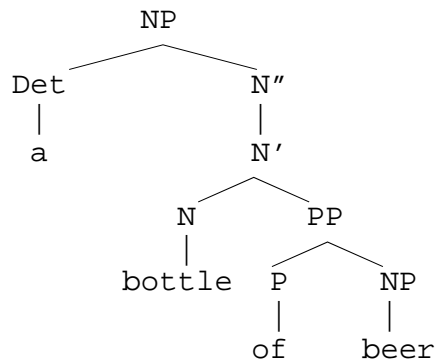

(3) is an example of a content reading, in which the measured noun *beer* is the head of the whole NP. The measure phrase *a bottle* occupies the position of [Spec,N''], which, according to Selkirk, roughly corresponds to that of indefinite quantifiers, such as *many*. On the other hand, the container reading in (4) is a complex NP whose head is the container *bottle*. The head selects a complement PP of *beer* which includes the content.

Selkirk uses three criteria to determine what the head of a Noun Phrase is: selectional restrictions, agreement and pronominalization. We have already seen that the selectional criterion differentiates two heads for the content and container readings, which is what (3) and (4) reflect.

The other two criteria have to do with the

identification of the phi-features of the NP as a whole. According to the traditional view, the head of the NP should define the phi-features once and for all, as in the following examples of possessive NPs:

- (5) a. The man's hats are falling from the hanger.
b. The men's hat is falling from the hanger.

In (5)a, between the plural possessed noun *hats* and the singular possessor *man*, the former is the head of the NP, as shown by the plural agreement with the verb. In (5)b, the head is still in the same position, but because it is singular, the agreement on the verb will be singular as well.

NPs also agree in phi-features with coreferent pronouns. Again, according to the traditional view, the head of the noun phrase determines those features once and for all.

- (6) a. Pick up the man's hats before they fall off the rack.
b. Pick up the men's hat before it falls off the rack.

When we apply the pronominalization test to the two NPs from (5), we find exactly the same pattern: the possessed noun is the head of the NP, and the coreferent pronoun agrees with it, whether it is plural, as in (6)a, or singular, as in (6)b.

However, the tests of agreement and pronominalization are not consistent with the results of selection in the case of Container-content NPs. Consider (7).¹

¹ I will use Spanish examples because the paradigm

- (7) a. Las botellas de cerveza_i [que bebí t_i]
 the bottles of beer that I-drank
 eran muy grandes.
 were very big
- b. Las botellas de cerveza_i [que rompí t_i] eran
 the bottles of beer that I-broke were
 muy grandes.
 very big

In the two examples in (7), the subject NPs have raised from relative clauses in which they satisfy the selectional restrictions of two different verbs. Thus, according to the selectional criterion, the subject in (7)a should be a Content reading, whose head is the singular content *cerveza* 'beer', and the subject in (7)b should be a Container reading, with the plural container *botellas* 'bottles' as its head.

Yet the agreement with the matrix verb is plural in both (7)a and (7)b. Therefore, we face a contradiction: by the agreement criterion, the container *botellas* is the head of the NP in both examples, but by the selection criterion, the content *cerveza* must be the head in (7)a, and the container *botellas* must be the head in (7)b.

(8) illustrates the same point with regard to pronominalization:

- (8) a. Rompí dos botellas de cerveza antes de
 I-broke two bottles of beer before of
 beberlas/*?la.
 drink-them/*it
 'I broke two bottles of beer before drinking
 them.'

exploits the discussed structures more fully than English. However, even where some marginality arises in the English translations, the facts discussed in this chapter hold for English as well as Spanish.

- b. Bebí dos botellas de cerveza antes de
I-drank two bottles of beer before of
romperlas/*la.
break-them/*it
'I drank two bottles of beer before breaking
them.'

In (8), the NP is the object of the matrix verb while binding a pronoun that acts as the object of the embedded verb. Regardless of whether the verb selects for a content or a container reading, the bound pronoun is plural in both sentences. Once again, there is a disparity between selectional restrictions and phi-features.

The traditional concept of head does not capture these facts. It cannot be true that the head of the DP must determine agreement and selectional features. We thus have to find an alternative analysis that does not rely on such a notion of head, and allows different parts of the DP to determine selectional and agreement properties.

1.2 Thematic Relations

Selkirk's analysis, as presented in the structures in (3) and (4), assumes that there is a fundamental difference in structure between the Content and the Container readings. In Minimalist terms, the thematic relations established by the two readings are different, given the two different configurations in which the nouns are merged.

I think such an analysis fails to capture the fact that the thematic or conceptual relation between the container and the content is the same in the two

readings. I want to argue instead that the thematic configuration is the same in the two readings, because both have the same initial structure. At the same time, logical or intentional syntactic differences, which will be highlighted below, are the result of different derivations.

Uriagereka (1995) shows that the same merging structure may yield totally different referents within a complex DP, not unlike the Content-Container DPs I am studying here. He illustrates this intuition using the following paradigm:

- (9) a. [The city's ethnic neighborhoods] are poor.
b. [The ethnic neighborhoods of the city] are poor.
c. [A city of ethnic neighborhoods] is always poor.

According to Uriagereka, at the lexico-conceptual configuration all three phrases in (9) express the same basic relation, which he calls *Integral*, following Hornstein et al. (1994). The typical case of an integral relation is the one that is established between a whole, such as *city*, and its parts, in this case *neighborhoods*. However, depending on the way the derivation proceeds, the reference of the whole expression ends up picking out the neighborhoods, as in (9)a-b or the city, as in (9)c, as clearly shown by verbal agreement and the interpretation of the DPs.

I will assume that Container and Content reading DPs are derived from a common initial configuration as well, and that the differences between them are determined by different lexical arrays and derivations.

1.3 Extraction and the Container-Content DPs

The structural difference between the content and container readings becomes more evident by observing that it produces a contrast regarding the extraction of interrogatives. Catell (1976) noted that those NPs that allow extraction are the same in which the main stress can only be borne by the content:²

(10) a. I bought a bók about that compôser.

b. Which composer did you buy a book about?

(11) a. I burnt a bók about that compóser.

b. *Which composer did you burn a book about?

Catell arrives at the conclusion that the content in (10) is actually its own NP, acting as an independent argument of the verb. The intuition is later picked up by Chomsky (1977) when he proposed an extraposition analysis of these NPs, in which the PP extraposes from the NP and finds an escape hatch that way.

(12) a. What did John write about Nixon?

b. He wrote it (=a book) about Nixon.

(13) a. *What did John see of Nixon?

b. *He saw it (=a picture) of Nixon.

Chomsky proposes that in the cases in (12) the container can act as an independent constituent, which can be questioned as in (12)a and even substituted for by a pronoun, as in (12)b. (13), on the other hand, is an

² Oehrle (1977) also comes close to finding the relevant correlation, when he points out that the different structures proposed by Selkirk (1977) could be used to explain the extraction facts.

example in which the container is not an independent constituent. The structures are as follows:

- (14) a. [_{VP} write [_{DP} a book] [_{PP} about Nixon]]
b. [_{VP} see [_{DP} a picture [_{PP} of Nixon]]]

An analysis such as (14)a may be on the right track, but is not complete. To be fair, the structure presented by Chomsky in (14)a may be possible for certain expressions (as (12) seems to suggest), but it is not the only structure allowed in the sentence. Furthermore, the difference cannot account for extraction, given that both DPs in (14) allow *wh*-extraction:

- (15) a. Who did John write a book about?
b. Who did John see a picture of?

Maybe certain container-content relations can be expressed as in (14)a or as in (14)b. However, I will stick to a structure as in (14)b, where there has been no extraposition.

The extraction contrasts between container and content readings are shown in more detail in (16)a and (16)b.

- (16) a. [De qué]_i bebiste una botella t_i
of what drank-you a bottle
'What did you drink a bottle of?'
b. *[De qué]_i rompiste una botella t_i
of what broke-you a bottle
'What did you break a bottle of?'

There is a clear contrast between (16)a, where the *wh* has been extracted from a content reading DP, and (16)b, where the host of the extraction is a container

reading DP.³

A similar contrast is found when extracting the measure phrase which includes the container:

- (17) a. ?[Cuántas botellas]_i bebiste t_i de cerveza
 how-many bottles drank-you of beer
 'How many bottles did you drink of beer?'
- b. *[Cuántas botellas]_i rompiste t_i de cerveza
 how-many bottles broke-you of beer
 'How many bottles did you break of beer?'

Extraction of the measure phrase out of the content reading in (17)a yields a certain degree of unacceptability, but fares far better than (17)b, where the equivalent of the measure phrase has been extracted out of a container DP. In light of this contrast, I propose the following descriptive generalization: extraction is grammatical from content DPs, but not from container DPs.

I will blame this contrast on the internal structure of the direct object, and not on the relation between the verb and its object, as suggested by Chomsky (1977), and most of the later literature on the topic. Diesing (1992) proposes that certain verbs force a presuppositional reading of their objects, which can only be achieved by moving out of the VP-shell to a specifier position, from which extraction is not possible. Destruction verbs are a typical case of verbs that require presuppositional objects. However, there does not seem to be anything wrong, in general, with extracting out of the object of a typical destruction verb like *break*, as in (18):⁴

³³ The contrast may be sharper in the case of (16), but it is also evident in (17).

⁴ Notice also that (18) is a clear example of what Diesing

(18) *Éstos son los vasos de los que rompí una caja.*
these are the glasses of the that broke-I a box
'These are the glasses that I broke a box of.'

(18) only has one possible reading, namely that it was glasses that were broken, and not the box, even though both can satisfy the selectional restrictions of the verb. Assuming that the extraction involved in relative clauses is of the same kind as the one we find in wh-questions, the fact that relativization forces a content reading of the complement supports the generalization expressed above: extraction is possible out of content DPs only.

1.4 Conclusion

In this section I have argued that the ambiguity between container and content readings of certain DPs shown by selectional properties cannot be analyzed by posing a different head for each reading. The dissociation of agreement and selectional properties suggests that the traditional concept of head must be abandoned to allow for a more dynamic model. I have also argued that the two readings exhibit an asymmetry with regard to wh-extraction and relativization. Content DPs allow extraction, whereas container DPs do not.

(1992) calls 'once-only action,' which in her analysis presupposes the existence of the destroyed object. Diesing points out that in the cases in which the action is interpreted as habitual, an existential reading of the object of a destruction verb is possible and extraction is grammatical. Such an interpretation for (18), however, is at least not necessary.

2 A New Proposal

In this section I want to explore the idea that the content-container relation is determined at the point of Merge, where lexical relations are established (in accordance with the general theory of theta-role assignment in Chomsky 1995). The thematic relation is kept constant across the two derivations that lead to the container and content readings.

Within this general view of things, Uriagereka (1995) explores the possibility that small clauses are what most categories bottom out as.⁵ Specifically, relations between nominal expressions like the ones of concern here are conceived of as conceptual Spaces topologically folded, or presented, in a certain way that determines their dimensionality. A typical category theory, the system recursively defines categories (of dimensionality n) from more elementary categories (of dimensionality $n-1$). Syntactically, a Space and its Presentation play the roles of subject and predicate of an integral small clause,⁶ respectively. Lexico-semanticly, the conceptual Space is determined according to the details of the Presentation imposed on it, which narrows its semantic range in certain characteristic ways.

The small clause is dominated by two functional projections, as in (19), which translate into a neo-Davidsonian semantics as in (20):

⁵ These Integral Small Clauses are not unlike the ones underlying possessives in Kayne (1993, 1994), Corver (1998) or Den Dikken (1998).

⁶ See Chapter 1 for a discussion of Integral Small Clauses in Hornstein et al. (1994).

that are contents or to things that are containers.

In my view, these features, when present, are [-interpretable] in the functional projections and must be checked off by a category that bears their [+interpretable] counterpart, which is part of either the Space or the Presentation of the small clause. Reference and contextual restrictions are thus taken to be optional formal features added in the numeration, as understood in Chomsky (1995). Different feature compositions yield different derivations that will lead to different semantic interpretations.

Given the recursive nature of the system, a DP may be type-lifted to a higher dimension, by entering a new SC, and becoming its Space, as in (23).

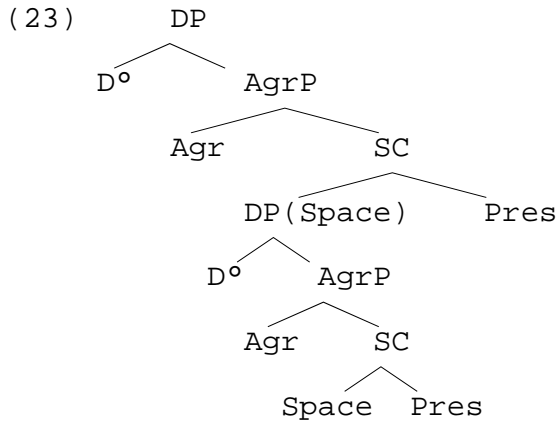

We saw in Chapter 1 how Muromatsu (1995) uses this system to articulate a hierarchy of DPs, ordered according to their syntactic complexity:

(24) 1D: Predicative use of nouns

chicken
(degree)

(25) 2D: Concrete mass term

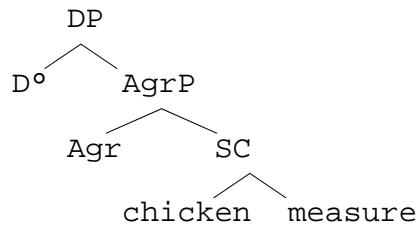

(26) 3D: Count noun

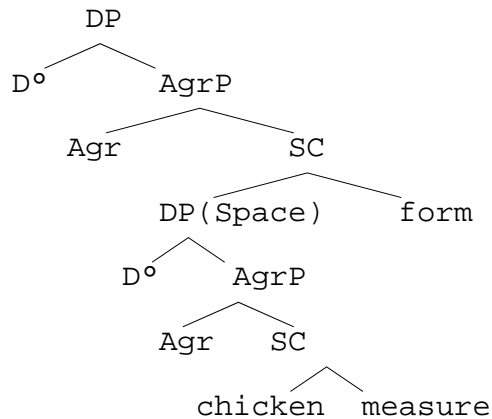

According to Muromatsu, 1D is a *pure* Space, in need of no Presentation. Measures materialize 1D into 2D. Classifiers individuate 2D into 3D, and so on.⁷ The dynamicity of this system allows Muromatsu to handle the changes in character that nouns can undergo in different syntactic contexts, as shown in the contrasts discussed in Chapter 1:

(27) a. There is chicken in this soup.

b. There is a (whole) chicken in this soup.

The noun *chicken* is manifested in these examples at

⁷ A similar study for the internal aspect of verbs is developed in Mori (1997). The presentation by way of verbal arguments of the previous verbal space folds an eventuality from a more basic type (e.g., a state) to a more complex one (e. g., an achievement).

all three different dimensions. (27)a is a case of a measured mass term, where we are talking of indeterminate chicken-stuff. Even though it bears a theta-role and refers to an entity, this sense of chicken cannot be counted. (27)b, in turn, is an instance of *chicken* as a count noun, with reference to the whole countable bird.

Also, recall that there is a unidirectional entailment relation in the examples in (27) from the higher to the lower dimensions: (27)b entails (27)a. This is expected if the structures are hierarchically ordered, as in (24), (25) and (26).

This system can be nicely applied to the container-content relations discussed in this chapter. Even though this assumption is not crucial, I will hypothesize that the container-content relation is established at 2D, where measure phrases act as predicates for mass terms. The relation between the content and the container will be defined in a SC, where the former is the conceptual Space and the latter is the Presentation that provides it with its specific dimensionality. I will further assume that this configuration underlies both the content and the container reading, given the system of entailments described in Muromatsu (1995), and additional data in favor of this claim.

In (29)a, the container bears the phi-feature plural and moves to the [Spec,AgrP] position to check [r]. In (29)b, the features are carried by the content, and thus it moves to [Spec,AgrP] to check [r]. As is obvious from the fact that in both sentences in (29) the verb is *beber* 'drink', the movement to the [Spec,AgrP] position does not affect the selectional relation between the verb and the object. The determination of agreement features, on the other hand, is directly affected. The member of the SC that bears the phi-features is the one that can check [r].

The determination of reference and of the phi-feature agreement is then a checking relation. Following Chomsky, I will assume that thematic relations such as selectional restrictions are not checking relations. This allows us to dissociate the selectional restrictions and the agreement features, as desired in light of the examples discussed in section 1.

2.1.1 Argumenthood of the Content

Given the potential split between selection and phi-features, it makes sense to ask which one of the two positions (the one that is selected or the one that checks [r]) hosts the argument of the verb that takes the whole DP as its complement. I will show that the Space is always the one that acts as an argument. The Presentation acts as a measure phrase, which shows the typical behavior of adjuncts.

Evidence that bears on this question comes from an

further research.

asymmetry regarding extraction. Cinque (1990), among others, shows that arguments can (more or less) successfully extract out of weak islands, such as the factives in (30), or wh-islands like (31), whereas adjuncts cannot.

(30) a. ?What_i did you regret [_{DP} the fact [_{CP} that John fixed t_i]]

b. *How_i did you regret [_{DP} the fact [_{CP} that John fixed the car t_i]]

(31) a. ?What_i did you wonder [_{CP} whether to fix t_i]

b. *How_i did you wonder [_{CP} whether to fix the car t_i]

When the test is applied to extraction out of content DPs, we can appreciate that the content (Space) can extract out of weak islands, as shown in (32).

(32) a. ?De qué lamentas el hecho de que
of what regret-you the fact of that
bebiste una botella t_i
drank-you a bottle
'What did you regret the fact that you drank a
bottle of?'

b. ?De qué te preguntas dónde beber una
of what you wonder where to-drink a
botella t_i
bottle
'What did you wonder where to drink a bottle
of?'

Presentations, on the other hand, cannot be extracted out of either island, as (33) illustrates.

(33) a. *Cuántas botellas lamentas el hecho de
how-many bottles regret-you the fact of
que bebiste t_i de cerveza
that drank-you of beer
'How many bottles did you regret the fact that
you drank of beer?'

- b. *Cuántas botellas te preguntas dónde
 how-many bottles you wonder where
 beber t_i de cerveza
 to-drink of beer
 'How many bottles did you wonder where to drink
 of beer?'

This is hardly surprising, given that Cinque (1990) also showed that measure phrases in general behave as adjuncts regarding movement out of weak islands, even when appearing in an apparent object position of a verb, as shown in (34).

- (34) a. *[How many pounds]_i do you regret the fact that
 she weighs t_i
- b. *[How many pounds]_i do you wonder whether she
 weighs t_i

Remember that at the 2D the Presentation still acts as a predicate over the conceptual 2D Space, without argumental properties. The Presentation cannot bear a theta-role from the argument-taking verb.

In light of these data, we see that there is a correlation between the ability of the Space to satisfy selectional restrictions on one hand, and to behave as an argument on the other. I take this correlation to be evidence in favor of a scheme like the one in (28).

Given that measure phrases (Presentations in my terms) do not show the syntactic behavior of arguments, I propose that Presentations are never arguments of the verb that selects for the whole DP, and thus never provide the features relevant to selectional restrictions.

2.1.2 Derivations of Content Readings

The structure of the content DP will thus be as follows. There are two possible derivations: one in which the container (*bottle*) bears the referential feature, and another one in which the content (*beer*) does. (35) illustrates the first case.

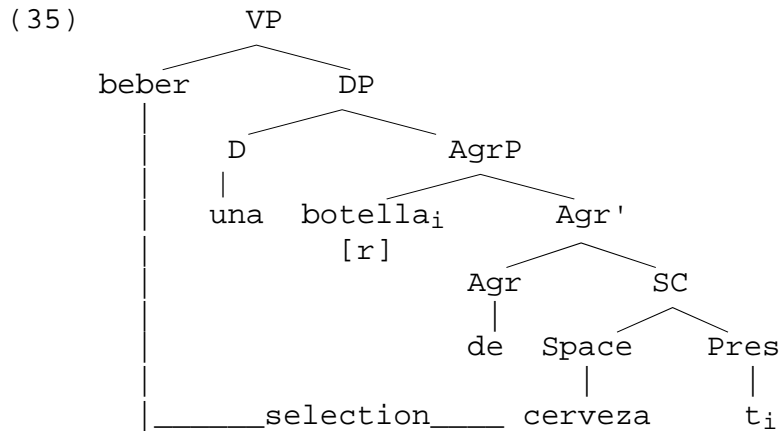

In (35), the container *botella* carries the interpretable referential feature [r] and thus moves to [Spec, AgrP], to check the uninterpretable feature of Agr⁰. As a result, the container also provides the agreement features for the DP. However, the selectional restrictions of the verb are satisfied by the content, *cerveza*. 'Bottle' is the referent of the expression only in the sense that it is the measure of the mass term, but the whole DP is still interpreted as a 2D object, namely a measured amount of a mass.

The second possible derivation is aptly illustrated by the Spanish example (36), whose structure is given in (37).

(36) Bebo cerveza de botella.
 drink-I beer of bottle
 'I drink bottled beer.'

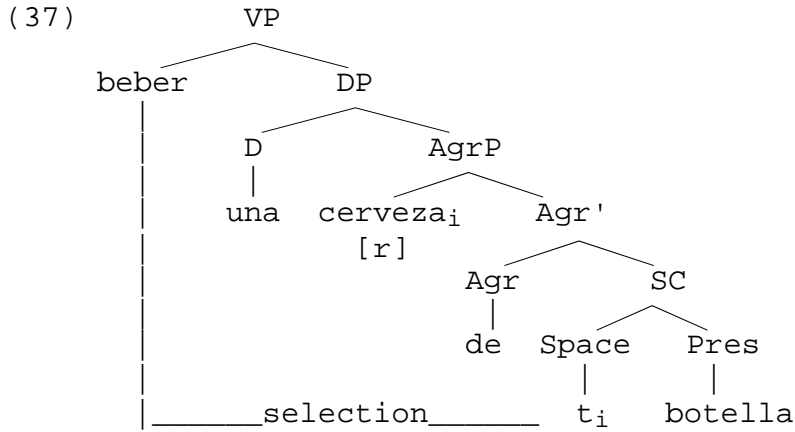

In (37), *cerveza* 'beer' contains the interpretable [r], and is thus attracted by the uninterpretable feature in Agr⁰. This is an instance in which the referent of the expression happens to be also the one that satisfies the selectional restrictions of the verb *beber* 'drink'.

The flexibility of the system allows us to capture cases in which intentional referent and conceptual dependent happen to be the same, like (36), as well as cases in which reference and selection are not associated with the same lexical item, like (35).

What defines the Content reading is the fact that the whole DP is still interpreted as a measured mass term, because the content, by virtue of being the lexical Space in the highest SC, satisfies the selectional restrictions of the verb. Container readings, starting with the same initial content-container relation, involve a more complex structure, as I will show in the following section.

2.2 The Container Reading

In order to get the container reading of an expression like *botella de cerveza* 'bottle of beer', we

need to raise the DP to the third dimension, where it can be interpreted as a three-dimensional count noun rather than a two-dimensional mass term. I follow Muromatsu (1995) in assuming that languages like Spanish and English employ a covert classifier, call it *pro-one*, which turns mass terms into count nouns. This procedure is directly observable in languages like Japanese, where a classifier must be added to a noun in order to make it countable.

I will further assume that the 2D structure underlies the 3D reading of the apparently identical structure, based on the following facts from English:

(38) a. I broke an empty beer bottle.

b. #I broke an empty bottle of beer.

From (38)b we can conclude that *bottle of beer* in container DPs cannot refer to an empty bottle. If there is no beer in the bottle, then the bottle is not really acting as a Predicate over beer, and the structure in (38)b is not licensed. In order to talk about a bottle which is a canonical container for beer but is empty, we need to use a different structure, namely *beer bottle*, where there is no implication that there is a container-content thematic relation. This is further illustrated by the fact that *beer bottle* cannot appear with a verb that forces a content reading, given that there is no content available in the thematic structure of the DP:

(39) #I drank a beer bottle.

If (39) has a reading at all, it would be one in which the bottle has been melted. But notice that in that case, it is not beer that is being drunk.

The presence of a content inside the container is

thus required when faced with the structure in (38)b, even though the DP as a whole receives a container interpretation. The natural way to capture this is that the 2D structure that expressed the container-content relation in fact underlies the 3D structure that allows the container to be selected by the matrix verb. I will thus propose the structure in (40) for the container reading.

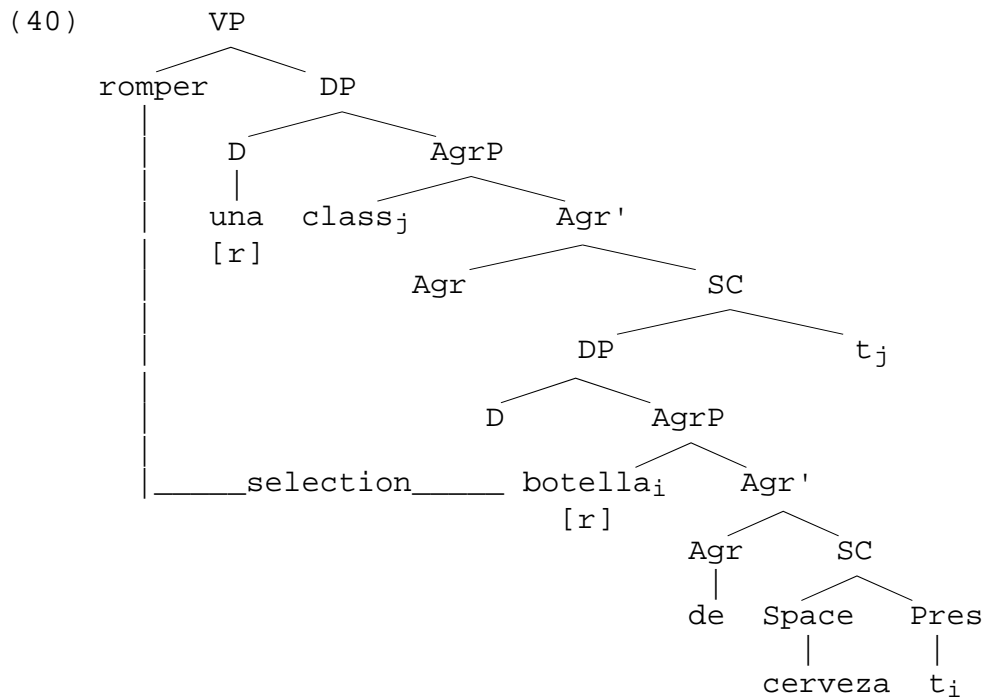

An effect of this structure is that the whole DP that used to act as a 2D nominal, is now a 3D Space, warped to the higher dimension by the predication of the classifier. The fact that it has become the subject of a higher SC explains the opacity to extraction under this reading, as we will see in the next section.

Notice that in this reading, the selectional restrictions of the verb *romper* 'break' are now being fulfilled by *botella* 'bottle', which was the Presentation

at the lower level. In the previous section, we determined that, at 2D, the Space of the SC enters the selectional restrictions of the matrix verb. However, that Space is now too deeply embedded inside the new Space for the 3D structure. The lexico-semantic features of the 3D expression are now provided by whatever noun checked [r] at the lower dimension, since that is the restriction of the quantifier for the 3D Space. The dynamicity of this system allows the change from one dimension to the next. Thus, in (40) *bottle* checks [r] at 2D, and becomes the referent of the Space when it is warped to 3D.

The analysis is supported by the impossibility of the Spanish example (41).

(41) *Rompí una cerveza de botella.
broke-I a beer of bottle
'(lit.) I broke a bottled beer.'

I will assume that the object in (41) has the same structure as the one we saw in (37), where *cerveza* 'beer' has checked the reference at 2D. By virtue of this operation, 'beer' has taken over the lexico-semantic features of the 3D expression, but it obviously lacks the semantic features necessary for the object of a verb like 'break', yielding the failing derivation in (42).

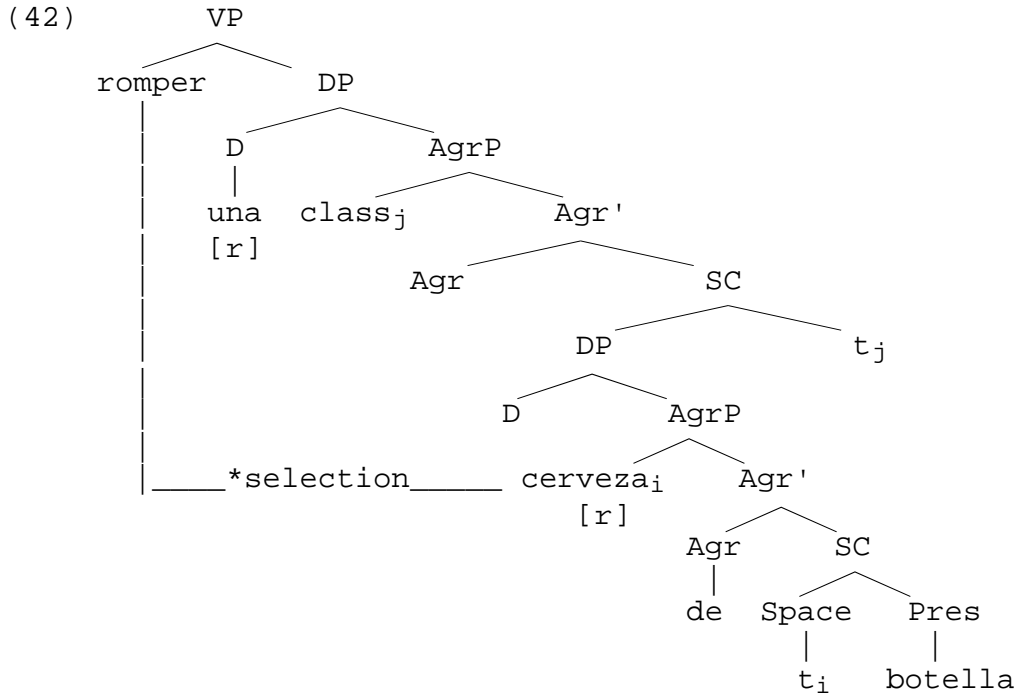

The derivation turns out to be uninterpretable, because of the selectional violation.

2.3 Back to the Content Reading

One of the main points of the analysis up to this point is that the position of the specifier of AgrP determines the features that enter into selectional restrictions when a DP forms part of a higher SC. We saw that when the container moves to that position in the lower SC, it becomes the object of the selectional features in a higher SC.

What we predict then is that movement of the content to the [Spec, AgrP] position must maintain the selectional status of the lower SC. That is, the content will still be involved in the conceptual side of the higher SC. The prediction is borne out, as shown in (43).

- (43) a. Bebí dos vasos de cerveza de botella.
 drank-I two glasses of beer of bottle
 'I drank two glasses of bottled beer.'
- b. *Rompí dos vasos de cerveza de botella.
 broke-I two glasses of beer of bottle

In (43), we see how when the Space of the lower SC checks the reference at the lower level, it can be presented again by a container at the next SC, in a structure like the one in (44).

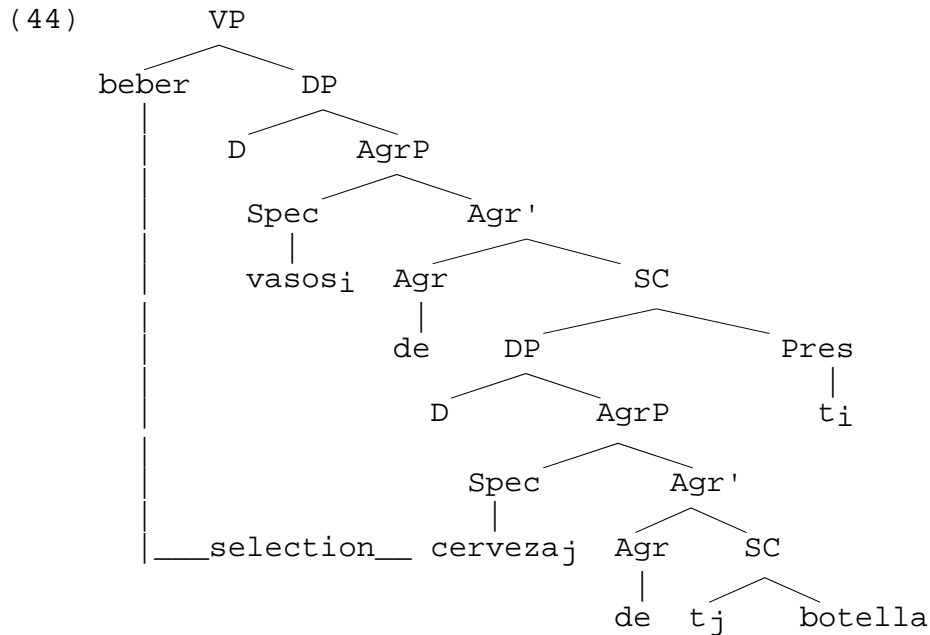

As we expect from the structure in (44), this sentence means that I drank two glasses of beer, which comes presented in a bottle. In this instance, the noun *botella* 'bottle' does not act as a measure phrase for the beer, but rather as a way of presentation, which characterizes the content as a special kind, the one that comes in bottles.

The ungrammaticality of (43)b then is the result of trying to embed the DP in (44) as the object of the verb *romper* 'break'. Such an attempt fails because, as is

clear in (45), the Space of the SC in the higher DP carries the semantic features of *cerveza* 'beer', resulting in a violation of the selectional restrictions of the verb.

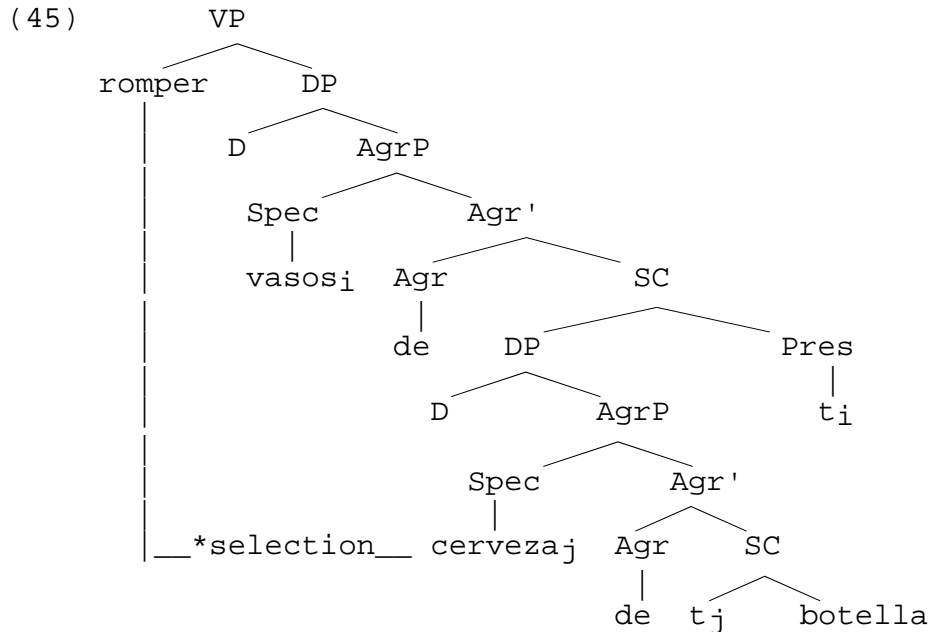

It is sensible then to ask what happens when the container moves to the referential position, and then we apply a measure phrase of some kind. The effect is quite interesting. The container can become a content now, and rightly so, because it provides the semantic features to the Space of a higher clause. Thus, we get an example such as (46).¹⁰

- (46) a. Rompí dos cajas de botellas de cerveza.
 broke-I two glasses of bottles of beer
 'I broke two boxes of beer bottles.'

¹⁰ There is an alternative reading of (46)b, which is grammatical, and asserts that I drank two cases of bottled beer. I take this reading to be the result of an alternative structure in which the measure for *cerveza* 'beer' is *caja de botellas* 'cases of bottles'.

- b. #Bebí dos cajas de botellas de cerveza.
 drank-I two boxes of bottles of beer

As we see, when the container moves to check the referential features in the lower SC, it feeds the selectional features of the higher SC, and can then satisfy the restrictions of a verb such as 'break'. Notice that the container now has become a mass term itself, and can thus be measured by an appropriate Presentation. The same syntax, however, gives us a selectional violation under the intended reading of (46)b, where the selectional restrictions of the verb 'drink' cannot be met by the Space defined by 'bottles'.

2.4 Conclusion

This section has presented a way to account for the structural differences between content and container readings which is embedded in the framework of a theory of DPs developed in Uriagereka (1995) and Muromatsu (1995). A content reading is a 2D expression, where the container 'bottle' is a mere measure for the mass term 'beer'. The container reading, on the other hand, is a 3D expression where the whole constituent 'bottle of beer' turns into a countable object, but at the same time embeds the 2D expression as a part of its structure.

The system also allows us to explain the asymmetries found between agreement and selectional restrictions, understood now as two processes of different nature. Selectional restrictions are configurationally determined, may only vary across dimensions but are fixed at the point at which the SC is merged. Agreement properties are defined in the course of the derivation,

through the checking of a referential feature, [r]. The next section will show how the extraction data are handled in this analysis.

3 Extraction Out of DPs

I have assumed the difference between container and content readings of DPs to be encoded essentially in terms of structural complexity. What looks like the object DP in a container reading is, in my terms, the subject of a small clause whose predicate is a (covert) classifier that lifts it from a (measured) mass term into a count noun. This analysis gives us an account of the extraction facts, as I proceed to show.

Recall that extraction is possible out of content DPs, but not out of container DPs. The data are repeated in (47) and (48).

(47) a. What_i did you drink a bottle of t_i

b. ?[How many bottles]_i did you drink t_i of beer

(48) a. *What_i did you break a bottle of t_i

b. *[How many bottles]_i did you break t_i of beer

What (47) and (48) show is that whereas the content DP allows extraction of both what we are calling the Space and its Presentation, the container DP does not allow any kind of extraction.

We have found the generalization for which DPs allow extraction, but we still have to understand exactly what disallows wh-movement in (48). Recall that, in my terms, the DP *bottle of beer* is the subject of a small clause in container DPs, and, as is well known, extraction out of

subject DPs is impossible in general:

- (49) a. *What was [a bottle of t] drunk at the party
b. *What do you consider [a bottle of t] (to be) an excessive quantity
c. *What are there [bottles of t] in this cellar

All the examples in (49) are instances of extraction out of subjects, as in passives (49)a, ECM clauses (49)b, and associates of expletives (49)c.¹¹ Obviously, what is common to (48) (if the structure in (40) is right) and (49) is that all of them involve extractions out of complex left branches.

As far as I can see, just about any traditional version of the so-called Subject Condition, which prevents extraction from subjects, would account for the phenomenon I have discussed in the terms I have analyzed it.¹²

It is not immediately clear how a different analysis could handle the data presented here. One obvious way would be to analyze the two structures as radically different. The following is a contemporary translation of Selkirk's (1977) proposed structures:

¹¹ I assume with Stowell (1981), Chomsky (1995), and contra Belletti (1988), Williams (1984), that the associate is not the object of the verb, but the subject of a small clause embedded under the copula.

¹² For instance, the Multiple Spell-Out analysis of left branch extractions in Uriagereka (1999a). Unlike Takahashi (1994), or Ormazabal et al. (1994), where the opacity of left branches depends on movement, Uriagereka's Multiple Spell-Out does not need to resort to uniformity of chains.

(50) a. *Content Reading*

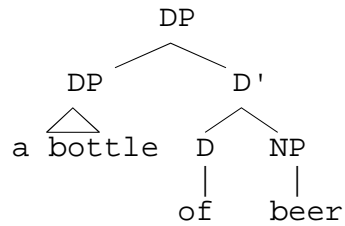

b. *Container Reading*

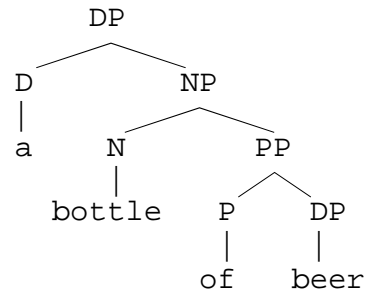

The details for the content DP do not diverge too much from my own analysis, except for the way in which the thematic relations are expressed. It could be argued that in (50)a the head of the NP provides the selectional features for the verb, but the specifier of the DP determines the phi-features, perhaps through agreement with D^0 , which could host the preposition *of* (incapable of bearing phi-features) or maybe be an abstract functional head.

However, there are problems with a structure for the container reading along the lines of (50)b. First, it fails to capture the entailment relation discussed in section 2.2 between the content and the container readings, which my analysis captures by making the structure of the content reading part of that of the container reading.

Also, it is not very clear what it means for the content to be the complement of the container. Extraction out of true complements of nouns, those derived from verbs, is much better than extraction out of container readings:

(51) What_i did you witness the destruction of t_i

Finally, if the structure of the container reading is anything like (50)b, the extraction facts cannot be

accounted for as straightforwardly as it may seem. Because the complement of N is in a right branch, in order to prevent its extraction a notion of *bounding node* would be necessary, something of dubious status in the Minimalist Program. Even though the analysis is possible, more stipulations would be required.¹³

A similar problem is faced by an analysis like the one proposed by Corver (1998). In his view, the difference between a content and a container reading is expressed in terms of whether the predicate of the SC is an NP or a PP. This difference, once again, fails to capture the entailment relation between the two readings. Regarding extraction, which Corver does not discuss, in his structure the content 'beer' appears in exactly the same position in both readings. This fails to predict the extraction contrasts discussed here.

I believe the analysis I have given is much more plausible under Minimalist assumptions. The extraction facts can be assimilated to other types of islands (adjunct, subject islands). Since these islands do not involve any kind of competition among wh candidates for movement, a structural explanation must be found for their ungrammaticality. The crucial point is the fact that the whole structure in a content-DP is part of a right branch, its subparts are available for extraction. On the other hand, the DP in a container-DP is a left branch, the subject of a SC, and shows the same opacity

¹³ Norbert Hornstein (p.c.) suggests the possibility that the container and the content stand in an adjunct relation. I will not explore the possibility here, even though the syntax of adjuncts and that of predicates in small clauses may be similar.

that other left branches do.

4 Further Extensions of the Analysis

So far I have discussed only very clear cases of relations between containers and contents, but the analysis can be carried over to more abstracts relations that show similar patterns:

- (52) a. Lisa está leyendo un libro de sintaxis.
L is reading a book of syntax
'Lisa is reading a book about syntax.'
- b. El director está quemando un libro de
the principal is burning a book of
sintaxis.
syntax
'The Principal is burning a book about syntax.'

As it was the case with *drink* and *beer*, when one reads a book about syntax, one is reading syntax, not strictly speaking a book as an object. The book simply happens to be a container of a subject matter. On the other hand, when one burns a book, one is affecting the container and not obviously the content. Thus, I claim that the difference between (52)a and (52)b is exactly the same as the one discussed throughout this chapter: (52)a is a content reading, (52)b is a container reading.

When we read a book about syntax, we understand syntax not as a whole, clearly, but as an instance of something like a mass term, arguably as in drinking beer. Sometimes, however, the subject of a book is not a canonical mass term, but a noun (phrase) which is usually understood as a 3D expression, a count noun, or an event.

(53) a. Bart is reading a book about Krusty the Clown.

- b. Lisa is reading a book about the Civil War.

It is precisely because of Uriagereka's (1995) dimensional theory that we can express such dependencies naturally. Nouns are not understood as inherently count, mass or proper. Rather, they can shift from one dimension to another. Similarly, nouns can be used as contents for different kinds of containers, even if a book may be an abstract container.

A typical objection to this idea comes from examples like (54).

(54) Lisa is reading a book.

However, this is as much of a counterexample to what I am saying as (55) is to the claim that we drink beer and not its container.

(55) Homer drank a six-pack.

With highly canonical containers, it is not necessary to express what the content is. A book is such a canonical container that the idea of a set of blank pages bound into a cover may arguably not be a book at all. And even if that is a book, it could not be the one described in (54), given that there is no content in it to be read. Needless to say, the same argument will apply to other containers of abstract contents at this level, such as movies.

These DPs show the same extraction patterns as the container-content DPs. We can talk about content and container readings, as shown by the selectional restrictions of the verb. Extraction is possible out of content readings only:

(56) a. De qué está leyendo un libro Lisa
of what is reading a book L
'What is Lisa reading a book about?'

- b. *De qué está quemando un libro el director
of what is burning a book the principal
'What is the Principal burning a book about?'

In (56)a, the content reading, extraction is possible. In (56)b, the container reading, extraction is disallowed. The data can be accounted for by postulating the same structures we assumed for DPs like a *bottle of beer*. Thus, (57) will be the structure for the content reading.

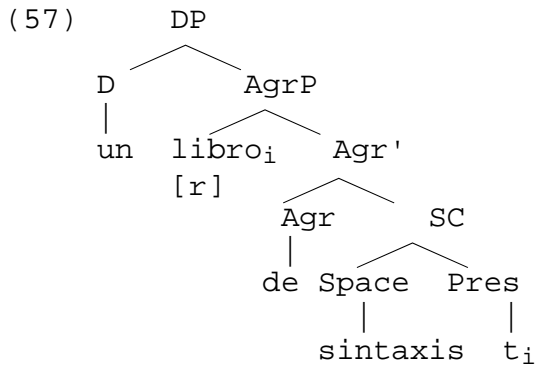

(58) will thus be the structure for the container reading.

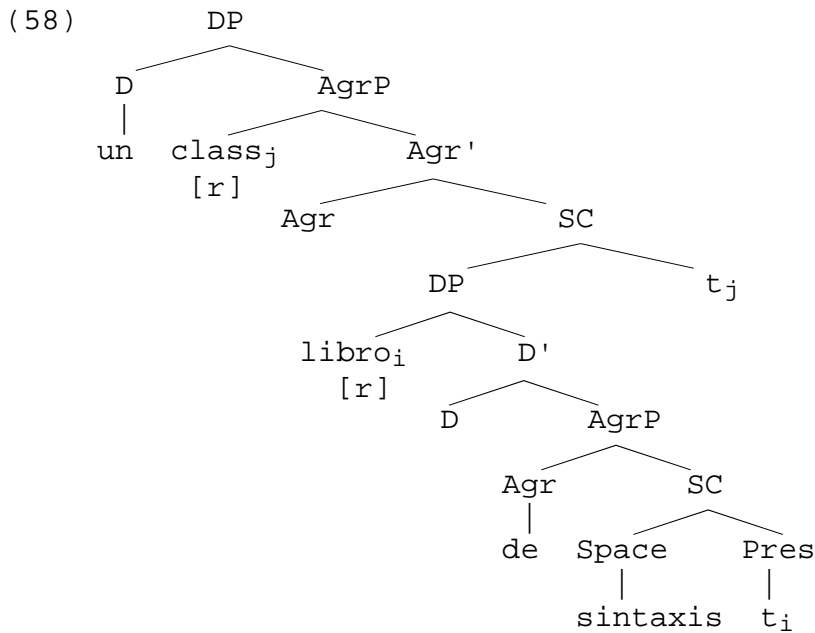

In this regard, once again, container readings behave exactly like subjects of different kinds, as shown in (59).

- (59) a. *What_i was a book about t_i censored by Principal Skinner
- b. *What_i did you consider a book about t_i to be inappropriate for children
- c. *What_i are there books about t_i in this library

As expected, extraction is not possible out of subjects of tensed clauses (59)a, infinitival clauses (59)b, or small clauses (59)c.

Finally, let me touch on the kind of DP that has been paradigmatically shown as an instance of these sort of extraction facts.

- (60) a. Who_i did Lisa see a picture of t_i
- b. *Who_i did Bart break a picture of t_i

Of course, so-called *picture-DPs* are going to be analyzed in the same way. I do not want to enter a philosophical argument regarding whether the image of Homer Simpson on a picture is really Homer or not. I am claiming that an image of a person is the Presentation of a conceptual Space, the way 'bottle' was a Presentation of the conceptual Space 'beer'-something with implications well beyond the scope of this dissertation. Once this is assumed, the facts in (60) follow trivially.

This section has thus extended the analysis of the container-content relation to instances of more abstract Presentations of conceptual Spaces. The analysis predicts that the syntactic behavior of picture NPs is identical

to that of container-content relations, and the data support this claim.

5 Conclusion

This chapter is based on three foundational issues: a refinement of the relevant data, a substantive conceptual proposal and a theoretical framework that allows a natural combination of both.

The correlation between the extraction facts and the interpretation of the object DP is in my opinion the major finding of this chapter. The fact that only content readings allow extraction and container readings do not has gone unnoticed until now. Such a contrast proves to be a challenging one for any theory, because of the issues involving selectional restrictions and agreement features. The contrast also favors a flexible theoretical framework, such as Minimalism, where the postulation of well-motivated features available to different nominal expressions allows us to capture the discrepancies between properties that were once thought as exclusive of a phrase's head.

The framework introduced in Uriagereka (1995) provides a major tool for defining thematic relations between nominals. It reduces them to a very basic syntactic configuration, the small clause, where no abstract thematic assigner needs to be postulated. The system also allows us to establish the difference between content and container readings of DPs in terms of structural complexity. This, on the other hand, provides a principled way to derive the extraction facts in pure minimalist terms. The proposal also captures the constant

thematic relation between the container and its content across a wide spectrum of constructions and interpretations. Uriagereka's system gives us the right thematic configuration to extend the analysis to other more abstract relations between nouns that behave syntactically in a surprisingly consistent way.

Finally, the Minimalist conception of the computational system provides simple tools for deriving a multiple array of structures from a basic thematic configuration. The different combinations of formal features assigned to the nouns in the small clause predict the paradigms presented throughout the chapter. Two semantically well-motivated features and a single thematic configuration, plus the requirements and constraints placed on derivations by the grammar (as understood under the Minimalist Program) are enough to explain the multifaceted phenomena presented in this chapter.

CHAPTER 3
MEASURES TO PARTS, MASS TO COUNT

This chapter will serve as a connection between two sections of this dissertation. The first section covered the behavior of mass terms when presented by Measure Phrases. In this chapter, I will draw a transition from the behavior of mass terms to that of count nouns. The hypothesis to be explored here is that the structure of a count noun is more complex than that of a mass term, and that in fact the latter underlie the syntactic structure of the former.

I will also work on the hypothesis that any noun may be used as a mass term or a count noun, provided a certain syntax. This will show that the difference between one and the other is syntactic and not lexical.¹

1. From Mass to Count

Uriagereka (1996) points out an interesting contrast found in Spanish:

- (1) a. animal de 100 g. de peso con varios órganos
animal of 100 g of weight with several organs
de estructura
of structure
- b. *animal de varios órganos de estructura con
animal of several organs of structure with
100 g. de peso
100 g of weight

Uriagereka hypothesizes that the contrast is due to a rigid hierarchy in the kind of elements that can act as predicates for nominals in possessive constructions. In (1)a, the noun *animal* is modified first by a predicate that takes a mass term, such as *100 g.*, which represents

weight, a characteristic of matter that does not necessarily imply the existence of form. This complex constituent is further modified by a predicate that selects count nouns, such as *varios órganos*, which implies a structure and thus a form. The structure that Uriagereka proposes for (1)a is thus as in (2).

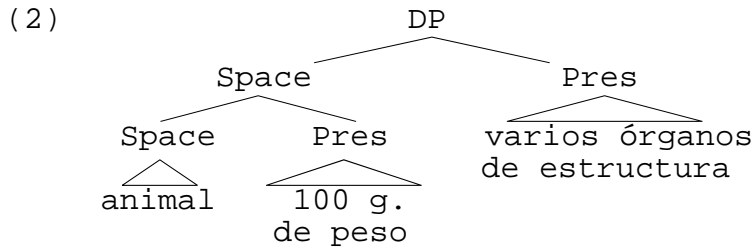

(2) is a legitimate structure because the noun *animal* is first modified as a mass term, and then as a count noun. The structure for (1)b is shown in (3).

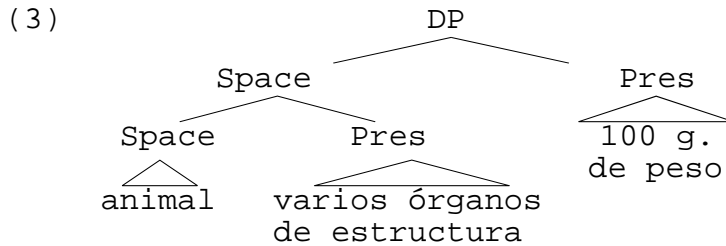

The problem for (3) is that by the time the mass modifier is inserted, the noun *animal* has already been type-lifted to a higher dimension, that of count nouns, by virtue of being modified by a predicate that implies the existence of form, and thus of individuality and structure.

This strategy shows that the nominal system exhibits both flexibility and rigidity in its configuration and type-definition. On the one hand, the system is flexible enough to allow different typifications of the same noun. This is evident in the sense that the noun can in principle be modified by either one of the two predicates,

¹ This is the view defended in Ritchie (1971), Sharvy (1978), Uriagereka (1995), Muromatsu (1995), Castillo

thus showing an ambiguity between mass and count, as shown in (4).

- (4) a. animal de 100 g. de peso
 animal of 100 g of weight
- b. animal de varios órganos de estructura
 animal of several organs of structure

At the same time, there is a rigidity that is the result of the system of conceptual dimensions proposed by Uriagereka (1995) and Muromatsu (1995). Recall that this system hypothesized different syntactic structures that gave rise to separate levels of complexity in the expression of noun phrases. These levels of complexity are organized in a fixed hierarchy that cannot be violated without incurring in ungrammaticality.

2 More Contrasts

2.1 Measures vs. Parts

The ambiguity between count and mass uses of the same noun can be illustrated with another contrast in Spanish between these noun phrases:

- (5) a. 100 caballos de motor.
 100 horsepower of engine
- b. *30 válvulas de motor.
 30 valves of engine
- (6) a. 1000 páginas de libro.
 1000 pages of book
- b. *126 capítulos de libro.
 126 chapters of book

According to the majority of contexts in which the nouns *motor* 'engine' and *libro* 'book' are used, they seem to be very solid count nouns. They admit numerals, take plural morphology and all the quantifiers that usually

(1998), among others.

accompany count nouns. Yet, in order to appear in this construction, they must be understood as mass terms, as implied by the appearance of the bare noun after the preposition.

I will argue that the explanation why these nouns must be interpreted as mass terms in the (a) cases, but cannot be understood as such in the (b) examples is nowhere in the lexical material or the morphology of the noun. It is all in the relation between the dimensionality of the noun and the predicate that presents it.

Horsepower work as a measure for an engine because they do not imply the existence of structure. We are simply measuring the capabilities of the object, the same way that we would measure its volume in cubic centimeters or its weight in pounds. And none of these types of measures care about the internal structure of the object.

On the other hand, valves are parts of an engine. Notice that the number of valves may be a very good measure of the size, power or performance of an engine in the extra-linguistic world, but not in language. Thus the ungrammaticality of (5)b. Notice that the same effect would be obtained if we used other parts, such as cylinders or sparkplugs. The expression would be ungrammatical because we are dealing with parts and not with measures, and parts are beyond the realm of mass terms.

Similarly for the book. A book like Cervantes' *Don Quijote* is an enormous book, both in the number of pages and in the number of chapters it comprises. However, only pages are a good measure for it. Chapters count as parts of a structure, and thus they imply a structure that the mass use of the noun in (6)b simply does not provide syntactically.

Notice that when the measure phrase is ambiguous, only the measure reading is available in this construction. Consider the following expression:

- (7) Juan tiene seis dedos de mano.
J has six fingers of hand

The word for finger in Spanish can be a measurement for length. As extraordinary as it would be that Juan had six fingers in his hands, that reading is impossible for (7). The only reading available is the one in which Juan's hand has five fingers of constituency, but six in length. A similar case in English would be if we used the expression *three feet of man*. This would describe a very short man, but it could never mean a three-legged creature.

As we have seen in these cases, a count noun can be forced into syntactic contexts where it is only usable with a mass meaning. This I will take as proof that the noun does not inherently come with a dimensionality of its own, and that it acquires its dimensionality when put in use in a certain syntactic configuration.

2.2 Quantifiers vs. Measures

Uriagereka (1993) discussed another instance of a mass use of supposedly count nouns:

- (8) En España hay mucho torero.
in Spain there.is much bullfighter
'In Spain there are a lot of bullfighters.'

We can find this use of a count noun with certain mass quantifiers such as *mucho/a* 'much', *poco/a* 'little', *tanto/a* 'so much', but not with *algo de* 'some', *un montón de* 'a lot of', *un poco de* 'a bit of', *cantidad de* 'a lot of'.

It must be pointed out that the interpretation of this mass use is very different from the one presented in this chapter. (8) gives us a reading that can be either

proportional (as in 'in Spain there is a higher proportion of bullfighters than usual') or perhaps contextually determined (as in 'in Spain there are more bullfighters than you would expect').

This interpretation contrasts with the one provided by measures, like the ones in (5)a or (6)a. The latter necessarily refers to an individual. If I am talking about *1800 libras de línea ofensiva* '1800 pounds of offensive line', the individual entity in question is a set of football players.

There is thus an implied sense of plurality in (8) that we do not find in (5)a or (6)a.

2.3 Singular vs. Plural

Another interesting contrast regarding the use of measures has to do with their behavior when measuring plural and singular nouns. Consider the following examples:

(9) a. 2.000 libras de coche.
2,000 pounds of car

b. Coche de 2.000 libras.
car of 2,000 pounds

(10) a. 200.000 libras de coches.
200,000 pounds of cars

b. #Coches de 200.000 libras.
cars of 200,000 pounds

(9)a-b are roughly equivalent. In both cases, we are talking about a car which weighs 2,000 pounds. It would be feasible to assign them the same structure and predicative relations. (10)a-b, on the other hand, mean two very different things. Whereas in (10)a, the measure is applied to all the cars as a group, (let's say, they form the cargo of a ship), in (10)b, the measure applies to each individual car, which explains its pragmatic oddity.

The analyses that follows will offer explanations for all the contrasts shown in this section.

3 An Analysis

3.1 Classifiers and Number

In languages with classifier systems, the proposed difference in complexity between mass and count uses of a noun is obvious. It has been repeatedly claimed that all nouns in such languages are lexically mass terms, and that count nouns do not exist in their lexicons (see Sharvy (1978)). Instead, a series of grammatical markers, called classifiers, are needed in order to individuate, and subsequently count, the tokens referred to by certain nouns.

The term classifier is thus a misnomer. Its use is related to the fact that classifier languages have a reduced number of these functional elements, distributed throughout the lexicon in a way similar to the class systems of African languages, the grammatical gender of Romance languages, or the declensions of Latin. As it turns out, classifiers do little classifying, and many authors have struggled to make sense of the semantic categories represented by each classifier. See Croft (1994) and references there for a review of these issues.

The far more interesting function of classifiers is that they allow counting of tokens. It would then be more adequate to call them individualizers, perhaps. However, I will follow the linguistic tradition, and call them classifiers, even though I will not be concerned with the issue of their noun-classifying function.

As I showed in chapter 2, languages without classifiers must use a similar process in the creation of count nouns. Doetjes (1997) proposes that the function of classifiers is realized by number in languages that lack

classifier systems. This hypothesis is sensible since languages with classifier systems tend to lack number morphology, according to Greenberg (1972).

In this chapter, I will take the view defended by Delfitto and Schrotten (1991) that number is not only expressed in plural, but also in singular, and thus, that there is a difference between three numbers in languages: lack of number, which corresponds to mass terms, singular, and plural.

Some Romance varieties show this distinction morphologically in a quite productive way. In Asturian a morphological marking appears on adjectives when agreeing with mass terms (and sometimes on the mass terms themselves) which is different from the one used with singular count nouns.² See (11) and (12) from Neira (1978):

(11) Ye fierr-o machaca-o.
It's iron hammered
'This is hammered iron.'

(12) Isti fierr-u ta machaca-u.
this iron is hammered
'This (piece of) iron has been hammered.'

Traditional grammars describe the mass term ending in Asturian as a neuter gender, often referred to as *Mass Neuter*, opposing it to masculine and feminine. However, Neira (1978) shows that this is completely inadequate. He instead proposes that this morpheme reflects a [\pm continuous] feature, whose import is similar to the one proposed in this chapter. The -o ending reflects "general matter, undefined with regard to the number of units comprised (...) non-countable," (Neira 1978:262; my translation) out of which individuals cannot be discerned. The -u ending is for "discontinuous matter, and thus,

² Juan Uriagereka (p.c.) points out that this is true of some Eastern dialects of Galician as well.

individualized, countable, for concrete as well as abstract concepts." (ibid.). The distinction drawn by Neira is thus very similar to the mass/count distinction discussed here.

I propose that in fact all languages are like Asturian, but in most cases the distinction between the presence and the absence of number is not morphologically realized. In many languages, the mass term shows the same ending as the singular count. As we have seen, the syntactic environment may be enough to distinguish these two, either by the absence of a determiner, or by the presence of a quantifier restricted to mass nouns. We have already seen some cases of bare nouns, such as (13)a and now we can add some cases of the second, such as (13)b.

- (13) a. Cien caballos de motor.
 100 horsepower of engine
- b. Algo de/un poco de/mucho motor.
 Some of a bit of much engine

Given these contextual clues, speakers of a language like Spanish can learn which uses of a noun are mass and which ones are count, even if there are no morphological differences between the forms of the two versions of the noun. The determiner system helps distinguish mass from count.

Thus, the number system we are describing for languages without classifiers is something as follows:

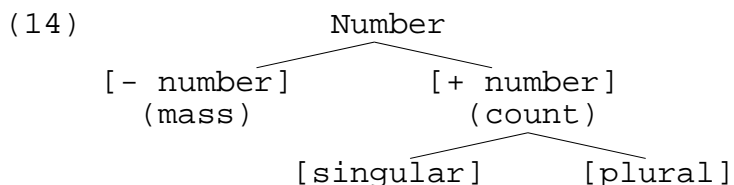

In many languages, there is no specific morphology for mass terms, but the syntactic structures in which the nouns are used help us determine whether it is being used as a mass term or a count noun.

I will follow Doetjes (1997) in assuming that, in languages with classifiers, the presence of these functional markers obliterates the need to have morphological number markings. I will further follow Delfitto and Schroten (1991) in assuming that the number feature is simply not realized in mass terms, rather than assuming that mass terms are marked singular. Thus the feature number is not an opposition between plural and zero, but rather a three-way distinction plural vs. singular vs. zero.

3.2 Absence of Number

I will assume the system proposed by Uriagereka (1995), and followed by Muromatsu (1995), Mori (1997) and Castillo (1998). According to this system, nouns are categorized by the application of predicates in small clauses. Depending on the nature of the predicate applied to the noun, it will be type-lifted to a certain dimension.

In the cases that we are dealing with, the measure phrase that modifies the nouns (5)a, (6)a and (7) is the kind that selects for no number. The expressions are readily interpretable because the noun with this absence of marking provides a mass interpretation.³

The structure I am assuming is represented in (15).

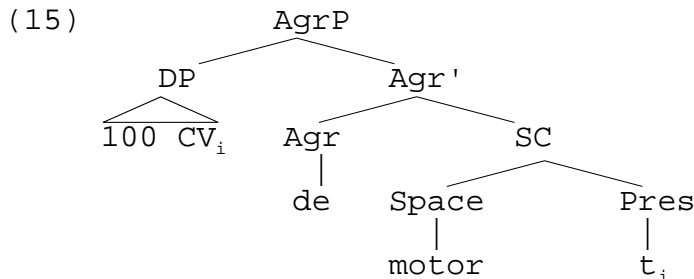

³ This interpretation implies the kind of join semi-lattice described by Landman (1991).

The noun *motor* 'engine' in this structure is a conceptual Space which is presented by a predicate that provides it with a certain dimensionality. Since the noun appears without any marking, it must be interpreted as a mass term. Given that *100CV* '100 HP' is a measure which can be applied to mass terms, the structure is grammatical.

When we try to apply the same structure to the ungrammatical cases in (5)b and (6)b, we find a problem between the Presentation and the Space of the SC. The predicate is not a proper measure for a mass term, which is the dimensionality that the unmarked noun holds. The noun *válvula* 'valve' is a part of an engine, and thus implies the existence of a form and structure that a mass term, with a two-dimensional semilattice structure, cannot offer.

Notice that similar structures are grammatical when the Space of the small clause has been warped to a higher dimension, and transformed into a count noun, as in (16) through (18).

(16) 30 válvulas de un/el /este/cada motor.
30 valves of an the this each engine

(17) 126 capítulos de un/el /este/cada libro.
126 chapters of an the this each book

(18) Seis dedos de una/la /esta/cada mano.
six fingers of an the this each hand

Notice also that the denotation of the whole structure in this case will be focused on the determiner or quantifier that presents the part, as it selects the count meaning of the noun. The numeral and the noun associated with it does not act as a measure of the Space that is being presented anymore, but rather as a part of an individuated entity.

This is strikingly similar to the difference between the container and the content readings discussed in Chapter 2. In both cases, we have a noun that acts as the conceptual Space to be presented, and another noun that acts as its predicate, and presents it with a certain dimensionality.

In the examples discussed in Chapter 2, the relation between the two nouns was kept constant (a count container and a mass content), but the whole constituent was either selected by the main verb as a mass term, or it was presented by a higher predicate that turned it into a count DP.

In the examples we are discussing here, we see how the choice of the predicate determines the dimensionality of the noun being presented. When the predicate is an adequate measure for the noun, the latter acts as a mass term, the dimension that I called content reading in Chapter 2. On the other hand, when the predicate stands in a part-whole relation to the Space, the latter must come already equipped with a higher dimensionality, similar to the one I called container reading in Chapter 2.

3.3 Singular vs. Plural Differences

Just like the container-content cases discussed in Chapter 2, the structure in (15) allows the Space to move to the referential position as well. This is exactly what we find in the example (9)b, repeated here as (19).

(19) Coche de 2.000 libras.
car of 2,000 pounds

Recall that this example measures a car. I assume that the structure is as in (20)

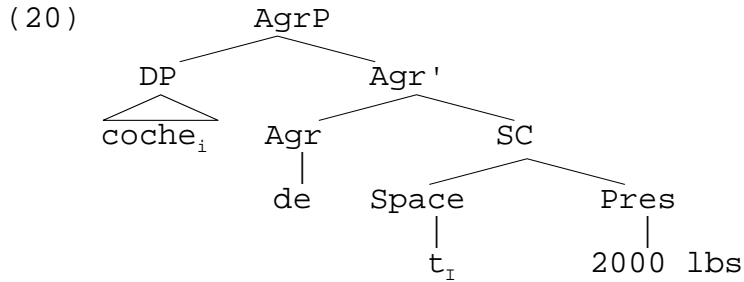

However, when the noun is plural, the interpretations differ. We saw that in (10)a, repeated here as (21), the measure phrase is applied to a plurality of cars.

(21) 200.000 libras de coches.
200,000 pounds of cars

The structure of this DP must then include a plural DP being presented by a measure predicate:

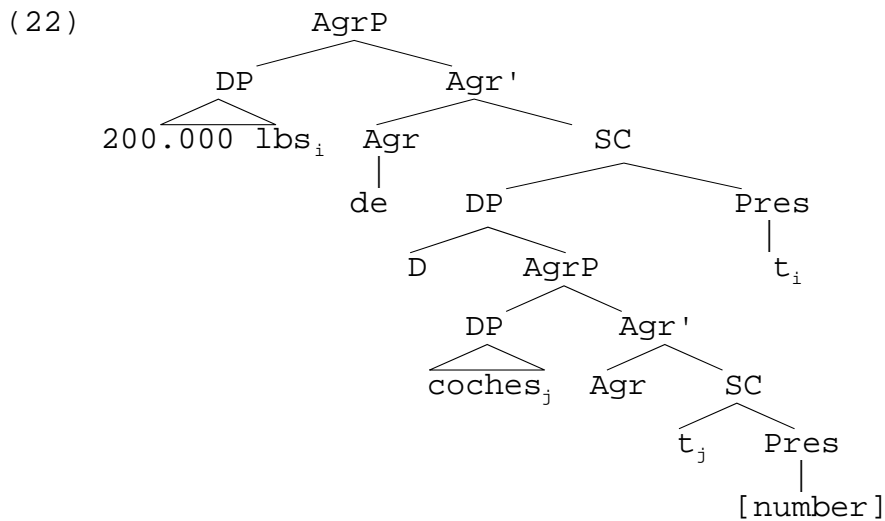

If the measure moves to [Spec,AgrP], the DP is grammatical, with the intended meaning: there is a plurality of cars that together weigh 200,000 pounds.

However, the Space cannot move to [Spec,AgrP] in this instance. (10)b, repeated here as (23), can only mean that each car weighs 200,000 pounds, and not that the plurality does.

(23) #Coches de 200.000 libras.
cars of 200,000 pounds

Thus, the only possible structure for (23) is the one in (20), where the measure is applied to an individual car first, and then Number applies to the whole structure:

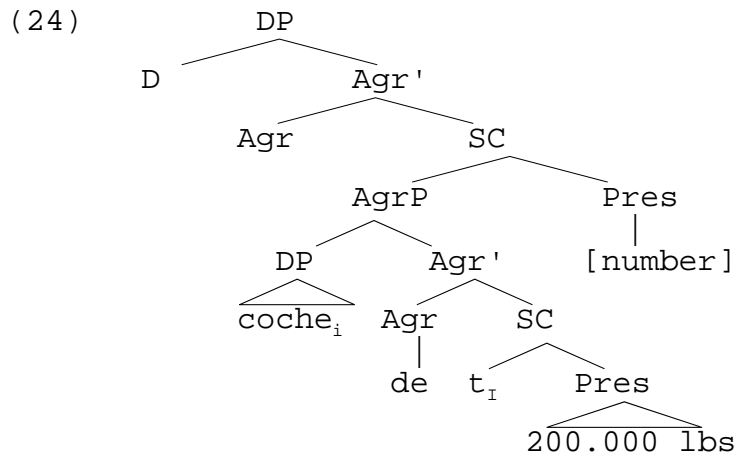

I do not have an answer to this problem at this point. There may be a constraint against Spaces moving to [Spec,AgrP], a derivation which certainly seems more restricted than those in which Presentations move to [Spec,AgrP].⁴

If movement of the Space to [Spec,AgrP] can only happen when the DP is the Space at a higher SC, then perhaps the movement of the Space in (22) could be outlawed by the need to have a second Number predicate at a higher SC. The result would contain two instances of Number applying to the same noun, presumably leading to uninterpretability.

I will leave the answer for future research, assuming that the analysis is on the right track.

There are two important points that I want to discuss in the next two subsections.

⁴ For instance, English generally disallows the movement of the Space instead of the presentation, thus ruling out expressions like *beer of bottle*, which, as we saw in Chapter 2, are grammatical in Spanish.

3.4 Warping and Non-Warping Presentations

First, certain Presentations warp a noun to a higher categorial dimension, but others do not. For instance, parts act as predicates for a count noun, but do not lift the type of the noun to a higher dimension. So the application of a part to a whole is not enough to turn a mass term into a count noun. Instead, a different kind of type-lifting predicate, such as a classifier, must be used.

Similarly, it may be that measures are not warping presentations either, contra what Muromatsu (1995) proposes. According to Muromatsu, measures warp predicative nouns into mass terms. In contrast, I think that measures must apply to nouns that already have enough syntactic structure to sustain a mass interpretation.

I leave this issue for future research.

3.5 Mass Nouns and Count Nouns?

Second, we must assume that nouns are not lexically defined for a certain dimensionality, but rather acquire the dimensionality in a syntactic context through the structure that applies to them. As we see, we can get mass readings of nouns that are generally used as count by not providing them with the number feature. This is an example of how a semantic concept such as David Lewis' Universal Grinder⁵ can be resolved in syntactic terms.

Similarly, nouns that are usually interpreted as mass terms can be counted by using several syntactic strategies, such as measure phrases or classifiers. Such processes allow us to create individual units in a concept

⁵ The Universal Grinder is metaphorically described by Pelletier (1979:5-6) as a machine that grinds any object

that otherwise is generally perceived as a continuum without individuals or parts. I agree with Chierchia (1998) that the factors that lead to canonical readings of nouns have more to do with pragmatics than with syntax or semantics, but I take the difference one step beyond. Chierchia, like Doetjes (1997), still admits the existence of a lexical distinction between mass and count nouns. Doetjes even proposes a three way distinction between mass mass (both cumulative and divisive), count mass (cumulative only) and count nouns (neither, at least in singular). She points out the following fact to support her distinction between the two types of mass nouns:

- (25) a. A piece of a piece of cake is a piece of cake.
b. #A piece of a piece of furniture is a piece of furniture.

According to Doetjes, *cake* in (25)a is a mass mass noun, because it shows the divisibility property. On the other hand, *furniture* in (25)b is a count mass noun because, even though it behaves like a mass noun syntactically, it lacks the divisibility property, and is actually composed of discernible individuals composed of parts.

I agree with Chierchia (1998) in the sense that the only difference between *cake* and *furniture* is a matter of extra-linguistic perception. Ultimately, in the real world, all mass nouns are count mass nouns, but sometimes the units are not readily perceptible. These units may not appear until the molecular level in some cases. I will thus not make a distinction between these two types of mass noun.

I will also assume that the likeliness of a noun to be used as a mass or count noun is based on pragmatic

into a homogeneous mass. It really refers to the ability of languages to use count nouns as mass terms.

factors, but that all nouns in principle have the ability to be used at different dimensions.

As we have seen, certain predicates do not change the type of a noun, but others do. In the next section, I will explore in more detail the role of number in turning a mass term into a count noun.

4 The Number Warp

4.1 Previous Accounts of Number

Number has been proposed to head its own functional projection inside the DP in numerous occasions. I want to review some of them here, and discuss the reasons why this category has been proposed.

Underlying the different proposals we find the spirit of Baker's (1988) and Pollock's (1989) seminal work on functional projections. The fact that number is an inflectional morpheme on nominal heads is enough to grant it status as a separate functional head. However, the motivation for the position of the phrase, its semantic import, and the generation of Specifiers with certain thematic characteristics are all largely unaccounted for.

Ritter (1991) creates NumP to justify some kinds of movement of the head noun out of its original projection, NP. Nouns in certain Hebrew DPs appear in front of their subjects, which Ritter assumes to be generated in [Spec,NP]. Furthermore, Ritter also assumes that adjectives adjoin to NP, and since the head noun also precedes the adjective, this is further evidence that the noun has moved out of NP.

Later on, Ritter (1992) gathers evidence from a variety of languages, including Haitian Creole and Hungarian, that supports her proposal for a separate NumP projection. An interesting analysis proposes two classes of pronouns: one is generated in D^0 (1st and 2nd person)

and the other in Num⁰ (3rd person), assuming that pronouns are generated in the functional periphery of the DP. Ritter shows how the latter class can follow the definite article in Hebrew, whereas the former class of pronouns is incompatible with it. Additionally, the form of the copula in present tense is the same as the 3rd person pronoun. Since present tense shows number agreement only on verbs, Ritter takes this as evidence that the 3rd person pronoun is the spell-out of Num⁰.

The only move in the way of a justification for calling this projection NumP comes from the inflection facts, and also the presence of some quantifiers in a position that looks like Num⁰ in Ritter's analysis. More controversial is the proposal that some possessors are generated in [Spec,NumP]. No attempt to an explanation of this is given, except to point out that possessors are not lexical arguments of nouns, a point raised already by Szabolcsi (1983).

Bernstein (1991) uses the NumP to propose a parameter that distinguishes Walloon from French. In French, the noun obligatorily moves to Num⁰, whereas in Walloon it stays inside the NP. This allows Bernstein to account for three differences between the two languages. First, the preferred order in French is noun-adjective, while in Walloon it is adjective-noun. This stems from the fact that post-nominal adjectives adjoin to NP below NumP. Second, French shows number marking on some irregular nouns, but Walloon does not, which follows, according to Bernstein from the presence or absence of movement of the noun to Num⁰. Finally, Walloon shows a feminine plural marking element between the adjective and the noun, which Bernstein analyzes as a separate head, rather than a suffix. This head is the realization of Num⁰, appearing once again in front of the noun.

Bernstein's (1991) analysis is again based in purely morphological facts, without much of a semantic motivation for the presence of the category NumP. A potentially substantial claim, namely the fact that pre-nominal adjectives in French adjoin to NumP rather than NP, is never connected to the special interpretation associated with these adjectives.

Bernstein (1993) adds another functional projection to the DP, this one called Word Marker Phrase (WMP), which hosts a morpheme which has been associated with gender, but Bernstein considers a noun-class suffix. NumP is justified on morphological grounds only (it is a more peripheral suffix than WM), but it also hosts a number of determiners in its Specifier position. It is significant that Bernstein separates the WM affix from NumP (as in Delfitto and Schroten 1991), arguing that some adverbs, which obviously must lack number, also show word markers.

Picallo (1991) simply puts forward a very radical view of morphological inflexion which assumes all inflectional affixes to be generated in separate projections. Since this paper deals with Catalan, which shows number inflexion, Picallo proposes a NumP projection, but again lacking substantive semantic motivation.

Delfitto and Schroten (1991) assume that there are three values for number in language: singular, plural, and mass, which corresponds to mass terms. They are forced into that conclusion by their analysis of bare plurals, which requires movement of the Num head to D. Given that, consistently across languages, bare mass terms behave like bare plurals, but unlike singular count nouns, Delfitto and Schroten propose that the content of the Num must be different for mass terms and count nouns.

I will follow the intuition in Delfitto and Schroten (1991) of a three-value paradigm for number, but I will

not argue here whether the mass number is a true number, the absence of it, or a zero-value for a feature.⁶ I will focus here on the function of number and how it affects interpretation.

4.2 Number as a Conceptual Warp

The thesis defended here is that number is a predicate that lifts mass terms from the second dimension they occupy onto the third one, which belongs to count nouns. Number is the syntactic expression of form, and plays the role that classifiers play in classifier-system languages. It has long been noted that there is a split among languages between those that have classifiers and those that have number (Greenberg 1972). I will defend here that they really are sides of the same coin, and really two different expressions of the same kind of predicate.

Mass terms exhibit the divisibility property, which is at odds with the presence of parts. Parts can be defined as individuals that play a functional or formal role in the make-up of another individual. Thus, in order to have a whole susceptible of having parts, we must be able to identify discrete individuals. Further, these individuals must not have the divisibility property. Thus a drop of water may be a discrete individual, but its composition lacks parts because it can be divided into smaller individuals which can also be referred to as water.

Even in the cases that Doetjes (1997) calls count mass terms, parts are not a property of the mass term. For instance, suppose we have the mass term *furniture*. According to Doetjes, *furniture* is a count mass term,

⁶ On the issue of zero values and ternary features, see the discussions in Ringen (1988) and Rooryck (1994).

because, in Chierchia's (1998) words, its smallest molecule is readily perceivable. So a *piece of furniture*, such as a table, refers to an object which can be easily perceived as an individual. As such, we can identify its parts: a table has legs, drawers, and a top. Even though it is a countable individual, we still can describe the table as *furniture*. However, the drawers, the table and the top are not parts of furniture, because *furniture* is a mass term and does not admit parts. Thus the contrasts in (26) and (27).

(26) The drawer is a part of the table.
The table is a piece of furniture
The drawer is part of the piece of furniture.

(27) The drawer is a part of the table.
The table is furniture.
* The drawer is part of furniture.

The fact that the first implication works but the second one does not is due to the fact that *furniture* is a mass term, as opposed to a *piece of furniture*, where a measure allows counting and thus individuation.

I hope I have shown that the concepts of mass and count are purely grammatical and are not rooted in reality. The fact of the matter is that when the same object can be referred to with a mass term or a count noun, the choice limits our expressive possibilities. Even though the object itself is composed of parts, and those parts are readily perceptible, we can only talk about parts if we choose the count noun. Thus, we can talk about the parts of a piece of furniture, or of a table, but they will never be parts of furniture.

In order to have a part-denoting noun be an adequate predicate to present a whole, this one has to have acquired the dimensionality that only number can provide. Thus, the structure of a count noun will have to be as follows:

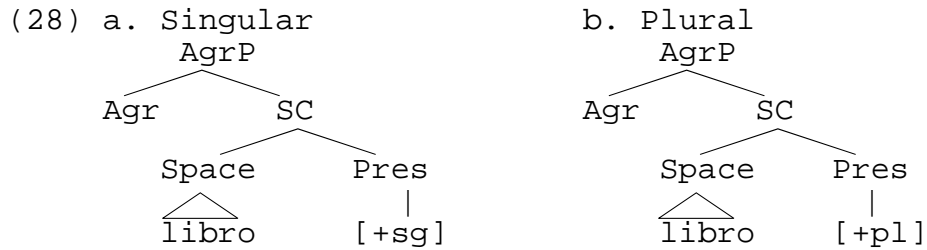

The noun without its number marking is understood as a mass term, and only acquires its count dimensionality when presented by means of number. From this abstract representation, the noun must check or acquire its number feature, depending on the theory of inflection that one uses.

The semantic function of number then must be what Chierchia called the SG function, which "checks whether a predicate foregrounds a set of atoms or not" (1998; p. 76). This function does not just "check", but actually seems to enable a predicate to foreground individualities, so that they can be available for counting.

In most languages, the singular marking is null, but we have seen the case of Asturian, where there is a singular marking, separate from both the plural and the mass marking. We have also seen how bare singular nouns can only be interpreted as mass terms, rather than count nouns.

4.3 The Scope of Number

As pointed out in Chapter 2, there are two readings associated with an expression that combines a measure phrase and a content or mass term. In this section I will use that analyses in connection with the properties of number and its position in the tree.

Consider again the cases discussed in (26). The expression *piece of furniture* is predicted to be ambiguous. On the one hand, it may refer to furniture, and thus behave as a mass term. On the other hand, it may

also be lifted to the next dimension, and thus be treated as a count noun.

This is achieved through the position of number in the structure. The structure for the content reading follows:

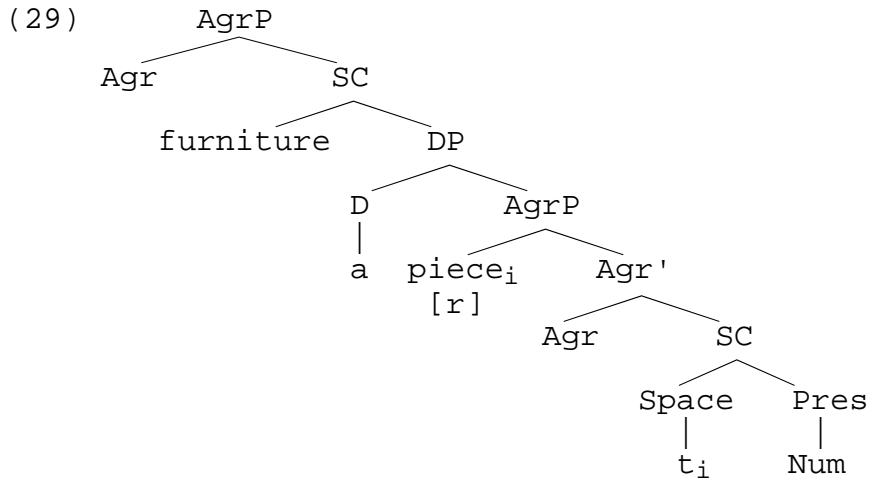

In the content reading, the number predicate is applied to the measure *piece* only, and has no scope over the mass term. This means that the number only serves to count measures, but does not warp the whole expression to the count dimension.

The measure moves to the higher [Spec, AgrP] position, as described in Chapter 2, thus yielding the Spell-Out structure *a piece of furniture*:

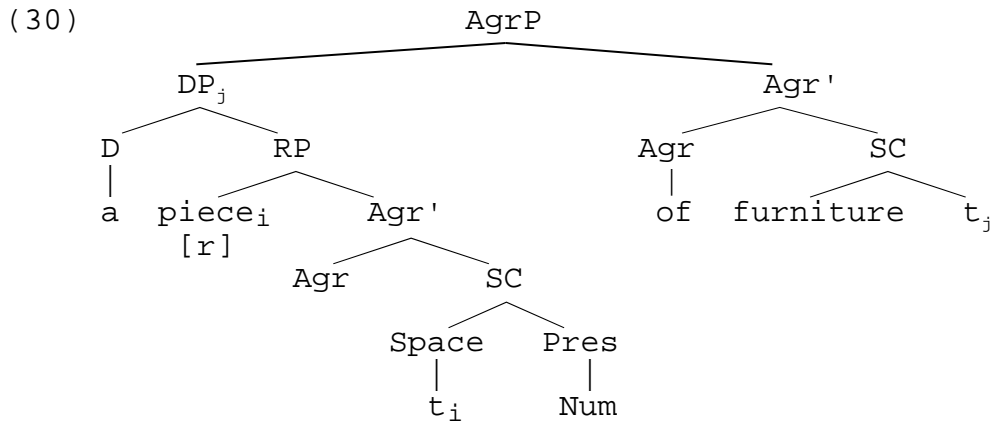

In the container reading, the number is a predicate for the whole expression *piece of furniture*, thus sending

it to a higher dimension, where the piece of furniture is interpreted as a count term, and thus is countable and allows a structure with parts.

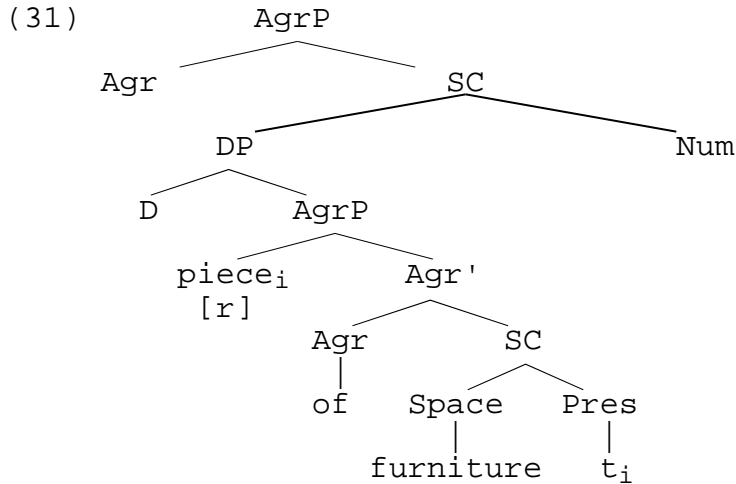

When we add the quantifier to this expression, it already comes equipped with the Number warp that allows counting, so the whole expression *piece of furniture*, and not just the measure *piece*, appears under the direct scope of the numeral quantifier. This is the structure necessary to be able to talk about *parts of a piece of furniture*. Since parts are properties of individuals, the lower structure must have been warped to the count dimension.

Thus, as the system described in Chapter 2 predicts, the expression *a piece of furniture* is actually ambiguous between a Content/mass reading and a Container/count reading. The difference between the two readings is expressed in terms of the scope of number. In the mass reading, Number only has scope over the measure phrase, thus not being able to lift the mass term to a countable dimension. In the count reading, Number has scope over the whole expression, and this can be interpreted as a count noun, which can be thought of as a whole with parts in it.

4.4 The Syntactic Nature of Number

Ever since it became its own syntactic entity, Number has been analyzed as a head of a functional projection in the exploded DP. As we discussed in section 4.4.1, the arguments invoked to justify this analysis are mostly morpho-syntactic, and have to do with the view that all inflectional morphemes should be considered to be heads of their own functional projections.

In these analyses, the way in which a noun acquires number is usually through incorporation of the Noun head into the Number head. Pre-minimalist views propose that the noun actually acquires the morpheme through this incorporation.

More standard Minimalist approaches propose that the noun already bears the morpheme Number from the numeration, and that incorporation into the Number head simply checks the feature. Under such a minimalist analysis, there are three possible reasons for the Noun to move to Number: i) the Number feature is uninterpretable in Num^0 ; ii) the Number feature is uninterpretable in N^0 ; iii) Num^0 has an EPP-like, uninterpretable N-feature, that triggers movement of N^0 , and the possibly interpretable Number feature of N is checked as a free rider.

i) seems to me to be inconsistent with an analysis that makes Number its own functional projection. Functional projections must have some kind of semantic import, and there is none left for a hypothetical NumberP if its Number feature is uninterpretable.

iii) can be dismissed on general grounds, if an EPP-approach to movement is disfavored, as in Castillo, Drury and Grohmann (1999).

We are left with ii), where we would have to assume that the Number feature as part of N^0 is uninterpretable in the numeration, and thus must move to get checked. This is the view of checking of features in Chomsky

(1995;ch.3), where the offending feature⁷ is assumed to be part of the moved element and not part of the target. This view also means that the interpretation of the noun as singular or plural is a result of its incorporation into Num⁰, and leaves the original feature on the noun as a mere justification for the movement itself.

A final alternative would be to make some maximal projection in the NP-layer move to [Spec,NumP] and perform the checking of Number in a head-specifier configuration. This approach would run into the choice of alternatives i) through iii) described above.

I want to propose a different alternative, where Number is not a feature that is checked morphologically, but is actually licensed through predication. Number is thus not a formal feature, but rather a thematic relation between the noun and a predicate, the Number head.

There is a possibility that the Number feature actually has to be licensed syntactically, but it is not licensed by the Number head. That licensing may be a requirement of the quantifier that binds the noun. Thus, quantifiers may require a different value for Number depending on their selection properties. Doetjes (1997) and Chierchia (1998) divide quantifiers into three classes: i) those that select count nouns, which can be divided between singular and plural quantifiers; ii) those that select mass nouns; iii) those that select mass or plural count nouns. Some quantifiers are unrestricted.

Quantifiers of the first kind can be assumed to select for a specific value for Number. Thus, singular quantifiers select for a nominal expression with singular Number, and plural quantifiers select for a nominal expression with plural Number.

⁷ The term "uninterpretable" does not appear with this sense until Chomsky (1995;ch.4).

Doetjes (1997) shows that mass quantifiers, type ii) above, usually appear as adverbs with adjectives and verbs as well. I propose that these quantifiers are incompatible with Number. Since in this system mass nouns have no value for Number, these quantifiers are predicted to appear precisely only with mass DPs.

iii) is a problematic kind of quantifier from a syntactic point of view. In our system, there is no syntactic category or configuration that includes these two classes of nouns. However, it must be noted that this is the case with other accounts as well. Both Doetjes and Chierchia resort to semantic categories in order to group mass terms and plural count nouns together. According to Chierchia, they are both plural from a semantic point of view.

According to Doetjes, both mass terms and plurals share what she calls a scalar q -position, where q stands for quantity. This position in the argument structure of the noun gives it the cumulative property that is typical of join semilattices, although not necessarily the distributive one.

In any case, we see that the third class of quantifiers is hard to define in syntactic terms. I will not attempt to do so here, but I will continue to pursue the matter in future research.

Number is really only invoked by the quantifiers that belong to the first type. Thus, Number on a noun, I propose, is not checked morphologically, but is actually selected by the quantifier that binds the noun and takes it as its restriction.

This account assumes then that Number is not a formal feature, and triggers no syntactic operations. Number is a predicate that stands in thematic relations like the one involved in the predication of the small clause, and the

selection relation between a quantifier and its restriction.

5. Conclusion

In this chapter, I have developed a theory of Number, which is meant to account for the language universal that languages with classifiers lack Number and vice versa. In order to achieve this goal, I propose that the semantic and syntactic role of Number is to turn a mass term into a count noun, thus allowing some of the properties normally associated with individuals: counting, the presence of parts, and the interaction with a restricted set of quantifiers.

I have also proposed that Number is not a traditional functional category. Number, like classifiers in languages that use them, is the predicate in an integral small clause whose subject is the mass term it modifies.

The analysis developed here also requires that nouns are not classified into rigid categories, but rather that they be allowed to appear as either mass or count, depending on the syntactic structure that accompanies them. This allows a natural analysis of certain productive shifts between count and mass found in Spanish.

CHAPTER 4
POSSESSOR RAISING IN SPANISH

This chapter attempts to give a detailed study of the issues involved in the Possessor Raising (henceforth, PR) construction in Spanish. Possessor Raising can be defined as the transformation that takes the D-structure possessor of the internal argument of a verb and assigns to it a surface grammatical relation (GR) to the verb of the sentence.

Given our theoretical assumptions, the analysis of Possessor Raising must be implemented in terms of Case. In some instances, a possessor gets Case internally to the DP. In others, the Possessor has the type of Case that cannot be checked by any head internal to the DP. When the Possessor has that kind of Case, it must raise out of the DP in order to get its Case checked by a head in the functional projections of the verb. The two Cases involved in the checking of a Possessor can potentially have very different natures.

Thus, when presented with a possessor, there are three logical possibilities: i) the possessor has a Case that cannot be checked internal or external to the DP; ii) the possessor has a Case that can be checked external to the DP (possessor raising); iii) the possessor has no Case that can be checked external to the DP, and is assigned Case internal to the DP.

Presumably instance i) never arises, because of a problem in the composition of the numeration for the sentence. According to Chomsky (1995), a numeration must contain all the items necessary for a convergent derivation. Instance i) will not be well-formed, given that there is a Case feature which cannot be checked in the course of the derivation.

Possibility ii) arises only in languages which allow

possessor raising, where some head in the extended verbal projection (in the sense of Grimshaw 1995) has an available structural Case-feature that can check the possessor's Case.

As for iii), it has been assumed that nouns can only assign inherent Case. Inherent Case is characterized by its ties to theta marking. A nominal can only receive Inherent Case from the same head that theta-marks it. This means that there can be no raising to an inherent Case position, given that theta-marking must happen in an initial merging position. Under these conditions, if inherent Case happens simultaneously with theta-marking, it should occur upon merging, and cannot be the result of a movement operation.

This would appear to entail that inherent Case marking is not a true instance of Case checking, since a checking operation tends to be the result of movement. However, this is not necessarily true. Some checking operations must be performed upon merging, as in the case of expletives. Expletives are never merged in theta-positions, so it follows that their insertion in a derivation must be induced by the requirement to check a feature of a certain head, be it agreement, an EPP feature, Case, or a combination of these features and perhaps others as well.

Inherent Case then could still be considered an instance of checking, so long as the configuration in which it happens is a Spec-head relation. However, not all theta-marking occurs in this type of configuration. When theta-marking happens in a different configuration, let us say, head-complement, and there is an inherent Case-marking happening at the same time, we cannot conceive of this configuration as a checking. It is not clear therefore, whether all inherent Case instances must be conceived of a checking or not. It seems natural to think

that all inherent Case markings should be uniform, whether they occur in a head-complement configuration or in a Spec-head one. Thus, I will assume that inherent Case is not a checking process, and that its nature should be different from that of structural Case.

Assuming that instance i) never arises, we are left with the choice between ii) and iii). If lexical items come from the lexicon into the numeration with full feature specifications, it follows that there will never be a choice between the two instances of Case, which correspond to different feature values. Given that this is not a choice, then no issues of economy appear. The derivations have different numerations and therefore cannot be compared for economy evaluation purposes.

On the other hand, it could be that inherent Case is a last resort mechanism. When a certain DP has no chance of getting its Case checked structurally, it may be able to receive Case in its theta-position from the head that theta-marked it. This may not be possible with all heads, but apparently it is possible in some instances, most likely with nouns, adjectives and possibly prepositions.

I will propose that possessors in Spanish can be Case-marked in these two ways. One is by inserting a dummy preposition that serves to license the noun in its base position. The other is by moving out of the DP where they are generated, and getting their Case checked by a higher functional projection.

1. Possessive Relations

Many authors agree that almost any two nominals can stand in a possessive relation. The examples that follow were discussed in Chapter 1:

- (1) a. John's sister.
- b. John's arm.

c. The truck's doors.

d. John's car.

Spanish (Uriagereka 1996:154)

e. Esta botella tiene cerveza.
this bottle has beer

f. Juan tiene vergüenza/hambre/conocimiento.
J has shame hunger knowledge

Tzotzil (Aissen 1987:129)

g. 7icham xa latzekale
died cl Agr-scorpion-Poss-cl
'Your scorpion (e.g. the one that bit you) has
already died.'

(1)a is a typical instance of kinship term. (1)b and (1)c are instances of inalienable possession, sometimes referred to as part-whole relation, which can apply to both animates and inanimates. (1)d is the paradigmatic example of alienable possession or ownership. (1)e represents a container-content relation like the ones studied in Castillo (1998). (1)f shows that animates can stand in a possessive relation with respect to emotional, physical or mental states. Finally, the Tzotzil example in (1)g shows how Tzotzil can use possession to express almost any relation between nominals relevant in context.

Trying to subsume all these different relations under a simple 'possessive theta-role' label is too much of a simplification, especially when one looks at the data more carefully and starts to see certain restrictions. For instance, (1)c can only refer to the doors that are an inalienable part of the truck, and not to a set of doors that happen to be the truck's load. The French sentences studied in Kayne (1975) that led him to disregard a Possessor Raising analysis, are limited to animate possessors and to inalienable relations only:

(2) a. On lui a cassé le bras
Impers him has broken the arm
'They broke his arm.'

- b. *On lui a cassé la vaisselle
 Impers him has broken the dishes
 'They broke his dishes.'

In light of subtle differences like these, it seems necessary to explore the nature of possessive relations more carefully before making overgeneralizations. This is the main purpose of this chapter.

2 Possessor Raising

2.1 A Description

I will follow the intuition expressed by Fox (1981) that Possessor Raising structures appear in instances in which a whole and a part, even though they hold different surface grammatical relations with respect to the same verb, are not really two separate arguments at the conceptual level. Fox claims that, at least in some instances, the presence of part-whole dependencies decreases the argument valence of the verb, thus turning transitives into intransitives, as in the Spanish examples in (3).

- (3) a. Juan se levantó.¹
 J cl-R lifted
 'Juan rose.'
- b. Juan levantó la mano.
 J lifted the hand
 'Juan raised his hand.'

The verb *levantar* 'lift' turns into the intransitive 'stand up' when the presence of a *se*-type pronoun denotes that the verb is in fact intransitive. Notice that, when used transitively, the verb loses the pronoun. (3)b is ambiguous between an alienable (Juan lifted any hand relevant in context) and an inalienable reading (Juan raised his own hand).

In the same manner, the presence of a possessive

¹ When I gloss the clitics, I will mark them as cl-D

relation can also mean that a sentence with an apparent ditransitive verb, is in reality a simple transitive. This is what we find in the examples in (4).

- (4) a. Juan se levantó la mano.
J cl-R lifted the hand
'Juan lifted Maria's hand'
- b. Juan le levantó la mano a María.
J cl-D lifted the hand to M
'Juan lifted Maria's hand'

(4)a only has the alienable reading, where Juan may use his left hand to lift his right hand, maybe because the latter is injured or disabled. Thus, in this instance, we have two arguments, which are Juan and the hand that is being lifted. Notice that (4)a is parallel to an example like (4)b, where the complex argument does not include *Juan*, but is a completely different referent.

The complex argument in (4)b is composed of *Maria* and *la mano*. Similarly, notice that (5) is a paraphrasis for (4)a, but not for (3)b.

- (5) Juan se levantó la mano a sí mismo.
J cl-R lifted the hand to himself
'Juan lifted his own hand.'

(5) shows that the sentence is formed by a complex object argument, in this case explicitly shown, and a subject getting an independent theta-role. The clitic *se* in this example is the reflexive form of the dative clitic, because the subject and the dative happen to be co-referential.

Thus we conclude that the example in (3)b is an instance of Possessor Raising to subject, and the ones in (4) are examples of Possessor Raising to dative. Both of these operations are allowed in Spanish, and are the result of different initial sets of lexical items.

(dative), cl-A (accusative), or cl-R (reflexive).

3. Clitic Doubling and Possessor Raising

Before I proceed to propose the specific analysis of possessor raising constructions, I will discuss the topic of clitic doubling. Clitic doubling plays a crucial role in possessor raising in Spanish, and this is why the two processes have been recently shown to be very intimately connected.

Clitic doubling is widespread in Spanish under different circumstances. Some examples follow:

- (6) a. Juan le dio un libro a María.
 J cl-D gave a book to M
 'Juan gave a book to Mary.'
- b. Juan le vio las piernas a María.
 J cl-D saw the legs to M
 'Juan saw Mary's legs.'
- c. Juan la vio a ella.
 J cl-A saw to her
 'Juan saw her.'
- d. Juan le vio a ella.
 J cl-D saw to her
 'Juan saw her.'

Virtually all datives allow doubling, and in some specific cases in certain dialects doubling seems to be obligatory. This is true of both goal indirect objects, as in (6)a, and derived datives, such as the raised possessor in (6)b. Also subject to dialectal variation, doubling of direct objects is allowed, whether by the accusative clitic, as in (6)c, or the dative one, as in (6)d.

Uriagereka (1995,1999) proposes an analysis of clitic doubling that has its roots in the ideas of Torrego (1998). According to them, the clitic is the head of a DP, and the double is its specifier.

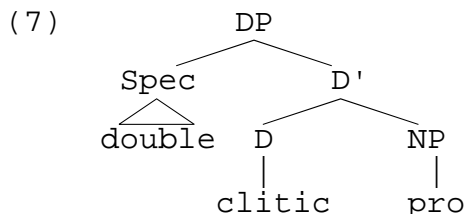

Uriagereka (1999b) draws a parallel between the structure in (7) and the one found in possessor raising sentences like the one in (6)b. Combining Torrego's structure with Kayne's proposal for possessives, we obtain the parallel trees in (8).

(8) a. Possessor raising

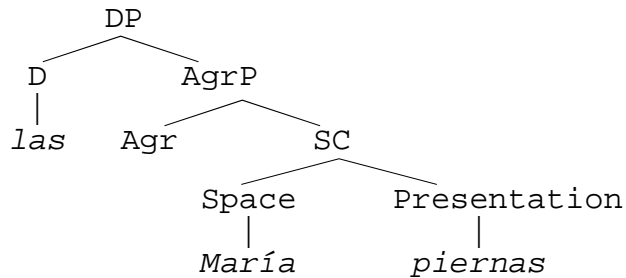

b. Clitic doubling

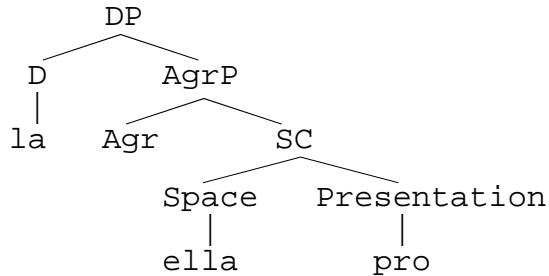

Recall the discussion of Hornstein et al. (1994) in Chapter 1, where the integral relation was introduced. According to Uriagereka (1998), we must understand the small clause in (8)b as an integral possessive relation between the full DP double and its persona, lexically realized as an empty pronominal *pro*. The integral relation is understood as a mode of presentation of the double, not too far from the examples that follow:

(9) a. El idiota de Pedro
the idiot of P

b. Pedro el idiota
P the idiot

'Pedro the idiot.'

These two expressions very clearly show the internal syntax of the DP. In both cases, the referent of the expression is *idiota*, which moves to [Spec,AgrP] to check

the [+r] feature. The difference resides in the syntactic behavior of the Space *Pedro*: in (9)a, it stays in the small clause, and Agr is lexicalized by the preposition *de*:

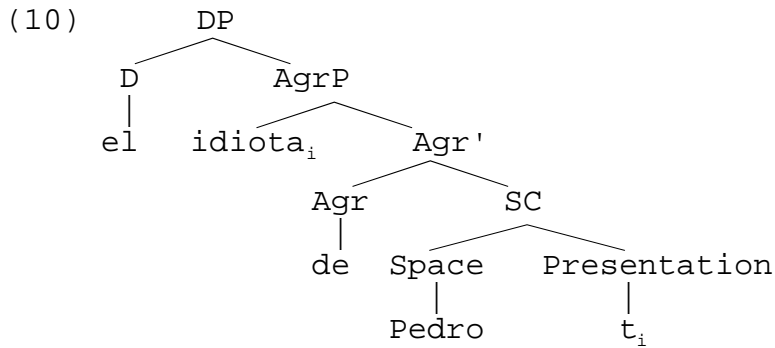

On the other hand, (9)b represents the alternative derivation in which the whole *Pedro* moves to [Spec,DP], thus making the preposition superfluous.

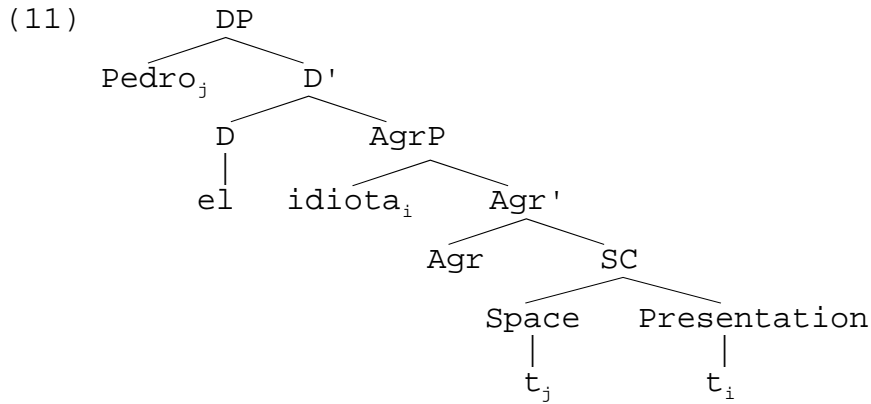

Uriagereka's idea is that the way *pro* presents a personal mode of *ella* in (8)b is the same as the one in which *Pedro* is presented in (9) as her idiotic self. The difference is that in this instance there is no lexical information associated with the presentation, so it is understood as a persona, in a sort of default interpretation.²

²Bleam (1999) ties the presence of this *pro* with the fact that doubling is associated with an affected interpretation of the double. Also, doubles tend to be animates, which are more likely to be associated with a

The structure in (11) will be common to all the instances of doubling and raising studied in this section. As it was first proposed by Szabolcsi (1983) for Hungarian, the double/possessor, in order to move out of the DP and have its Case checked,, it must stop at [Spec,DP]. This movement is supposedly motivated by a contextual confinement feature [+c], which resides in the D-head. Also, the *pro*/part must move to [Spec,AgrP], where it checks the referential feature [+r].

My analysis will tie the dependence in Spanish between the movement through [Spec,DP] and the DP-external Case-checking that triggers Possessor Raising. Basically, I will assume that [Spec,DP] is not a Case-checking position in Spanish, and thus any possessor that moves through this position must obligatorily move further to have its Case checked.

There are two possible exceptions to this. First, some instances of *pro* in doubling structures may be thought of as having their Case checked in [Spec,DP]. If that is true, then the restriction on [Spec,DP] in Spanish may be limited to phonologically realized possessors.

Second, there are examples like (9)b, where apparently a full DP appears in [Spec,DP] overtly. Given that this DP is necessarily coreferential with the whole DP, it is reasonable to think that Case may be transmitted internal to the DP. Also, notice that the cases involving *pro* in clitic doubling may also involve coreference between the double and *pro*. Then the restriction on [Spec,DP] could be that it can only be a Case-checking position when there is coreference with [Spec,AgrP]. The issue grants further research.

Given that possessors take a reference independent from that of their possesseees, I will assume that they

persona. See Uriagereka (1999b) for a possible extension

cannot have their Case checked in [Spec,DP]. Thus, we expect externally raised possessors in Spanish to show all the properties associated with the [Spec,DP] position.

Uriagereka (1999b) takes advantage of the parallel structures in (8) to explain the similarities between the cases of dative clitic doubling and possessor raising to dative presented here under (6). We explore the different analyses in the following sections.

3.1 Clitic Doubling with *la*

The first of the cases analyzed is the one where the doubling clitic has the accusative form *lo/la*, which corresponds to the accusative clitic. This use is restricted to some dialects, mainly in the Southern Cone of South America. We saw an example in (6)c, repeated here as (12).

- (12) Juan *la* vio a ella.
J cl-A saw to her
'Juan saw her.'

Uriagereka assumes that the homomorphism between the clitic and the definite article is not pure coincidence, and indicates that the clitic starts in fact as the head of the DP. When its complement AgrP is lexically filled, as in the structure in (8)a, D^0 stays in situ, and appears in its typical DP-internal position. However, when its complement is empty phonetically, as in the clitic doubling structure in (8)b, D^0 incorporates into the higher *v*, thus appearing in its typical clitic position.

This incorporation has a double effect. On the one hand, it determines the form of the clitic, so that accusative clitics are always incorporated D^0 s. Additionally, the incorporation serves to Case-mark the big DP, complement of the verb, so that it need not move

to inanimates.

to a higher position. Recall that, according to Szabolcsi (1983), [Spec,DP] is a DP-internal source of Case. Uriagereka (1999b) assumes that this is only true in Spanish when D^0 does not incorporate into a higher head. In this instance, then, there is no DP-internal source for Case for either of the two nominals left without Case: the double, and *pro*.

But the second effect of the incorporation is that it frees up the Case that can be checked by *v*. Thus, the Cases for the double and for *pro* are checked at LF, respectively, by *vDat* and *vAcc*.³ The final structure is shown in (13).

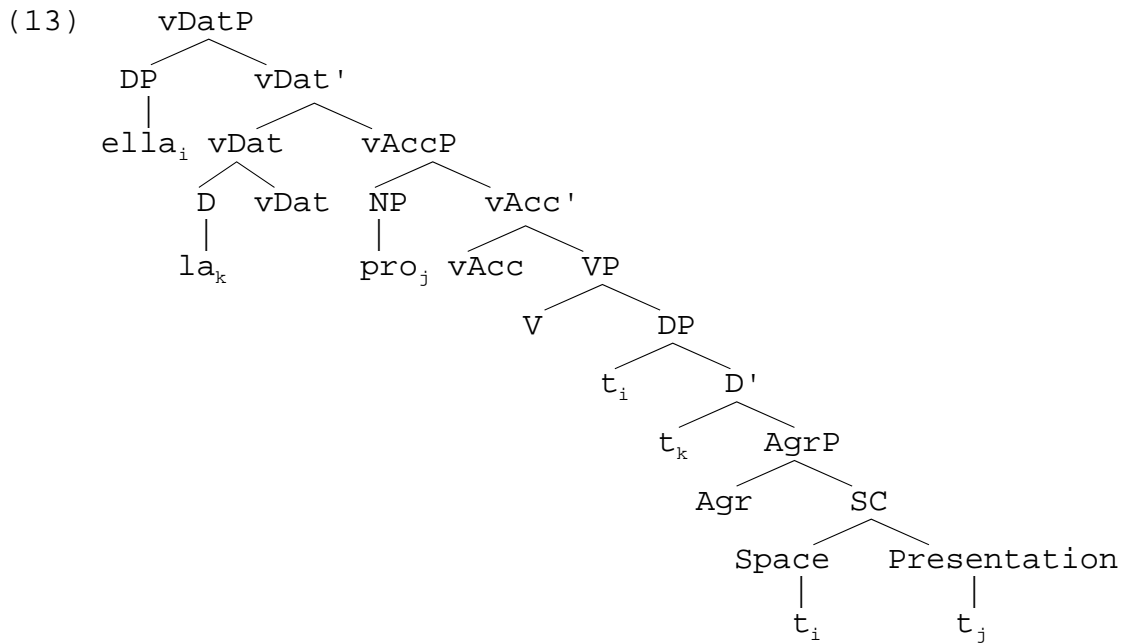

This analysis forces us into several assumptions that will drive the analysis of clitic doubling with the dative form *le*.

³ Notice that Uriagereka assumes that the order of the two functional projections has *vDat* higher than *vAcc*. There are good reasons to believe that this is the right order in Spanish, as I will discuss in Ch. 6. Sportiche (1995), based on the order of French clitics, proposed the opposite order. This may be a matter of parametric choice, and it is quite possible that French and Spanish simply select different options.

3.2 Clitic Doubling with *le*

In this section, I will present the analysis that Uriagereka (1999b) proposes for clitic doubling, when this involves the use of the dative clitic *le*. This doubling is typical of indirect objects in general, but it also arises in certain dialects, mainly Castilian, as the preferred form of doubling for direct objects. We saw an example in (6)d, repeated here as (14).

- (14) Juan *le* vio a ella.
J cl-D saw to her
'Juan saw her.'

Recall from the previous discussion that Uriagereka, based on Torrego's ideas, assumed that the accusative clitic is a form of a determiner. He does not apply the same analysis to the dative clitic, for several reasons. First, the form of the dative clitic *le/les* does not resemble that of the definite article *el/la/los/las* the way that of the accusative clitic does. Second, the number agreement between the dative clitic and its double is not as consistent as the agreement of the accusative clitic, which leads Uriagereka to believe that this agreement is triggered in a functional projection outside the DP.

Thus, the assumption will be that the dative clitic is not generated in the head of the DP, but rather as the head of the functional projection $vDat^0$. More specifically, $vDat^0$ will be realized as *le* (or *se*, in a restricted set of instances) precisely when D^0 does not incorporate into it. This means that we are dealing here with an alternative derivation to the one seen in (13).

First we will follow the movements of the double. The dative clitic *le* is generated in $vDat^0$, and the double has to reach its Spec in order to get its Case checked. On the way, it stops in [Spec,DP], a position which we have seen, serves as an escape hatch for extraction out of DPs.

(15) is the partial structure for the doubling example.

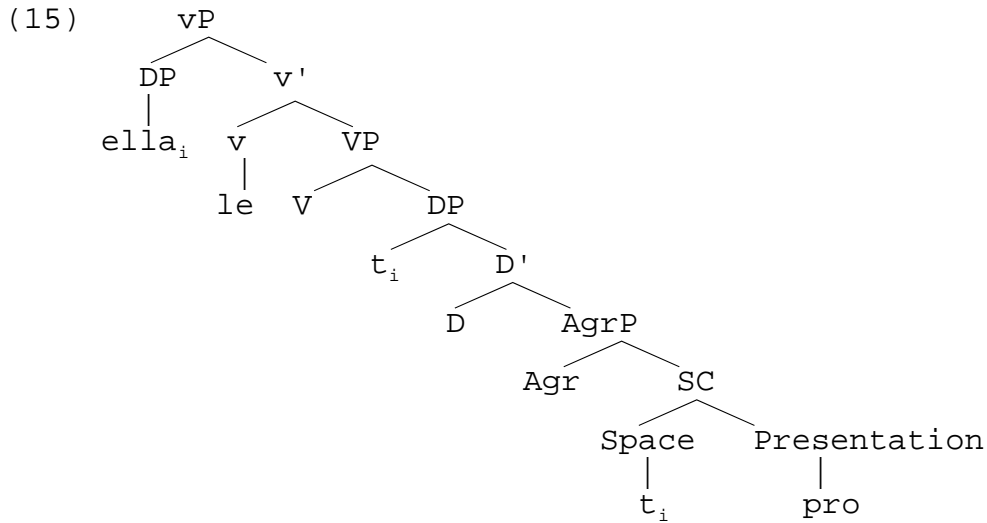

As for *pro*, once it has checked the referential feature [+r] in [Spec,AgrP], it needs to have its Case checked. Because D^0 has not incorporated into a higher head, it is a possible source of Case internal to the DP, and it does so in an outer [Spec,DP]. Finally, the big DP checks its Case against $vAcc^0$, which has not discharged its Case yet. (16) is the completed LF derivation.

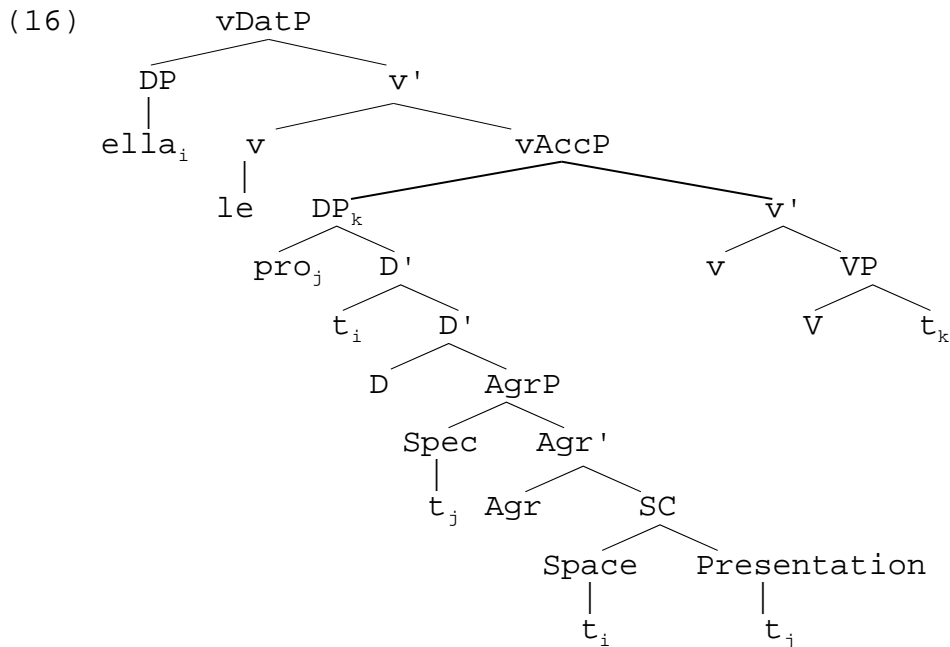

A final detail has to do with the realization of D^0 .

It is not realized as a definite article because it is not followed by lexical material. It cannot be realized as the accusative clitic either, because it has not incorporated into v^0 . Descriptively, under these conditions, D^0 is null, and is predicted to be null in any instance of dative clitic doubling.

This analysis can be easily transported, with minimal modifications, to account for the possessor raising to dative instances. We turn to these next.

3.3 Possessor Raising with *le*

The only difference between the clitic doubling example (14) discussed in the previous section and the possessor raising example in (6)b, repeated here as (17), is that there is lexical material following the head of DP:

- (17) Juan *le* vio las piernas a María.
J cl-D saw the legs to M
'Juan saw Mary's legs.'

The analysis of this example is the same as the one seen before, but this time, because of the presence of a part that follows the determiner, this is overtly realized in the form of an article. The final LF structure, then will be as follows:

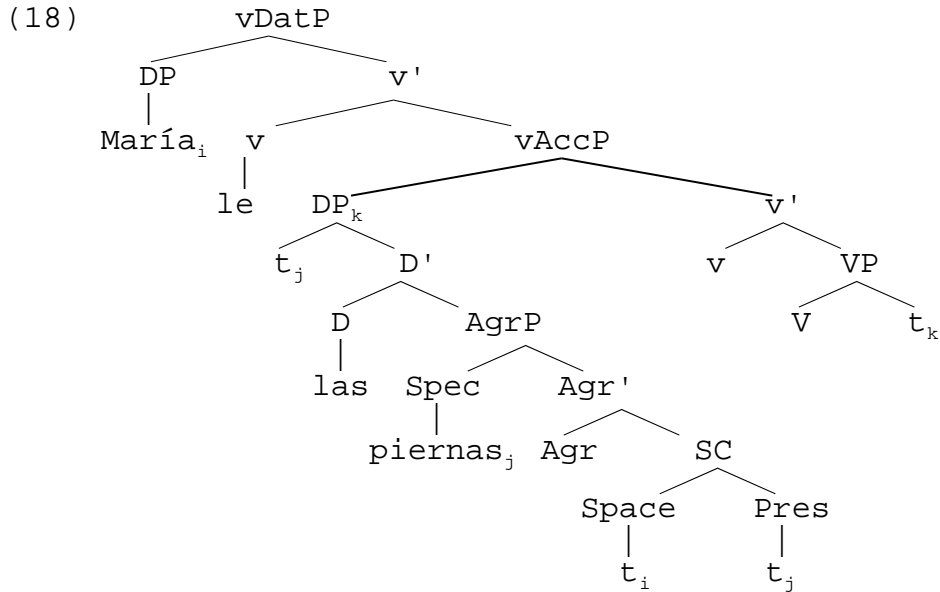

Uriagereka suggests that the part *piernas* 'legs' may move to [Spec,DP] at LF to have its Case checked. I will not assume that this is true. Instead I propose that the part, being the referent of the big DP, has its Case checked as the big DP moves to its Case position in vAccP.

3.4 Affectedness, Animacy and Other Restrictions

It has been pointed out that there are certain interpretation restrictions on doubled objects, as well as raised possessors. This restriction comes in different forms, but is usually associated with either an animacy restriction (doubles must be animate), or an affectedness restriction (doubles and raised possessors must be affected in a broad sense).

According to Uriagereka (1999b), the way this restriction is implemented is by making the double or the raised possessor stop at [Spec,DP]. Movement through this position checks a contextual confinement feature [+c], which has the effect of severely restricting the interpretation of the possessive relation at the time that the verbal event takes place.

A different take is that of Bleam (1999), who defines

the animacy/affectedness restriction as a requirement that the dative-marked nominal is a participant in the event. When the raised possessor is animate, then participation in the event is always, by their nature, a possibility. When the raised possessor is inanimate, then it has to be interpreted as affected in order to be licensed as dative. Blear's proposal for the syntactic implementation of this requirement is that the dative clitic bears a [+A] animacy/affectedness feature, and only arguments satisfying the requirement can move to its specifier.

Finally, Blear points out that doubling of direct objects is impossible with inanimates. The reason for this is that the *pro* that acts as a predicate in the small clause can only be interpreted as animate. This prevents the presence of doubling with inanimates, whether they are affected or not, given that the lexico-conceptual structure cannot be generated to start with.⁴

Again, the answer to these questions lies in the connection between possessor raising and [Spec,DP]. Because the latter is not a Case-checking position in Spanish, any possessor that stops in it will have to move out of the DP to have its Case checked. If Blear's affectedness can be tied to Uriagereka's notion of

⁴ Uriagereka (1999b) provides a sort of counterexample from the Cordoba dialect in Argentinian Spanish, citing data from Marcela Depiante. In this dialect, which has the peculiarity of doubling with accusative clitics, it is possible to double an inanimate object, but with an aspectual restriction. The doubling of *sonata* in (i) refers to a specific performance of the *sonata*. That explains the ungrammaticality of (ii), with an iterative reading, which implies several performances of the same *sonata*.

- (i) Yo la toqué a esa sonata.
I cl-A played to that sonata
'I played that sonata.'

contextual confinement, then it makes sense that all dative-marked possessors are affected, because a dative possessor must have stopped in [Spec,DP].

The specific interpretation of the restriction is not important in this case, but, as we will see in later sections, the requirement on dative possessors will play a role in explaining certain contrasts in possessor raising constructions in Spanish.

3.4 Conclusion

The elegance in the analysis by Uriagereka (1999b) resides in the fact that it explains a series of parallels between the three constructions involved here: the clitic doubling with *la*, the clitic doubling with *le*, and the possessor raising with *le*. All the examples are explained with a common underlying structure, but the composition of the lexical items and their morphology triggers different derivations, yielding the paradigm of cases presented in (6).

In the next section, I will try to apply the same analysis to a different set of data, one in which the nominals end up in different positions: mainly, instances of what I will call subject clitic doubling, and possessor raising to subject.

4. Raising to Subject

In section 3, I discussed the analysis proposed by Uriagereka (1999b), which takes as its starting point the common conceptual structure of the integral small clause for both clitic doubling and possessor raising. The main idea is that, in clitic doubling sentences, a null

(ii) #Yo la toqué a esa sonata durante horas.
I cl-A played to that sonata for hours

pronominal element, *pro*, stands in the same position occupied by the part/possessed in the possessor raising sentences. The make up of the lexical items and their morphological properties determines the eventual derivation.

I will use the same parallel to analyze the cases that I have claimed are intransitive instances of verbs that appear to be transitive. The two I am interested in were introduced in (3), and are repeated here as (19).

- (19) a. Juan se levantó.
J cl-R lifted
'Juan rose.'
- b. Juan levantó la mano.
J lifted the hand
'Juan raised his hand.'⁵

I will analyze these examples as being instances of clitic doubling for (19)a, and possessor raising for (19)b. Of course, following Uriagereka (1999b), these two phenomena truly are one, but with different initial numerations.

It is crucial to this part of the analysis to assume that in these two examples the verb assigns just one theta-role to the big DP, and not two, as the normal transitive reading of the verb does.⁶ Parsons (1990) calls these constructions direct motion, and points out that they do not imply a causative sense, the way most transitive verbs do. In Parson's neo-davidsonian terms,

⁵ Recall that (19)b has a second interpretation (see Parsons 1990:116), where Juan is lifting any hand that may be relevant in the context, and whose possessor is not being expressed. This reading is irrelevant to the discussion, and its structure likely does not involve an integral structure at all.

⁶ For instance, the second reading mentioned in the previous footnote, is a typical case of a transitive verb with two arguments, one external, and one internal. This instance would not follow Fox's generalization, since no two arguments stand in an integral relation.

there is no sense in which these constructions have two separate events, and thus he analyzes these verbs as intransitives.⁷

Verbs like *levantar* can generally be used either transitively or intransitively. The two uses translate into English as two different verbs, but I will not assume completely different lexical entries for the two uses of *levantar*. Instead, I propose that verbs of this kind must have the lexically specified option of having two theta-roles, or just one.⁸

In section 5, I will discuss some evidence that suggests that these verbs are not truly transitive, even in the cases in which they appear to have two arguments in the surface, as in (19)b.

4.1 Subject Possessor Raising

I will analyze first the instance where the possessed/part is phonologically realized, such as (19)b. As always, we have to consider how all the nominal elements get their Cases checked.

The part/possessed moves to the [Spec,AgrP] position, as seen in the dative examples in section 3. In this instance, the determiner is realized as a definite article, given that it is followed by lexical material.

The possessor moves through the [Spec,DP] position,

⁷ Following an idea in Dowty (1979:125).

⁸ The analysis shares the intuition expressed in Quintana (1998) with respect to reflexives and reciprocals, but I, in contrast to Quintana, will not be assuming an additional theta-role for the subject position, since these verbs describe what Parsons (1990) called *direct motion*. Thus, it is not the case that there is an event involving two individuals, but rather an event with only one individual, and one of its inalienable parts. Juan Uriagereka (p.c.) points out the possibility that the clitic *se* suppresses a theta-role. I will not study the possibility here.

where the contextualization happens. At this point, it also becomes the closest DP to the subject position, whose EPP/nominative feature must be checked. The possessor thus moves to subject of the sentence in [Spec,TP], from the internal argument position.

Since the verb *levantar* is lexically transitive, it has an accusative feature that must be discharged. Thus, the big DP, including *la mano*, moves to [Spec,vP] at LF.⁹

(20)

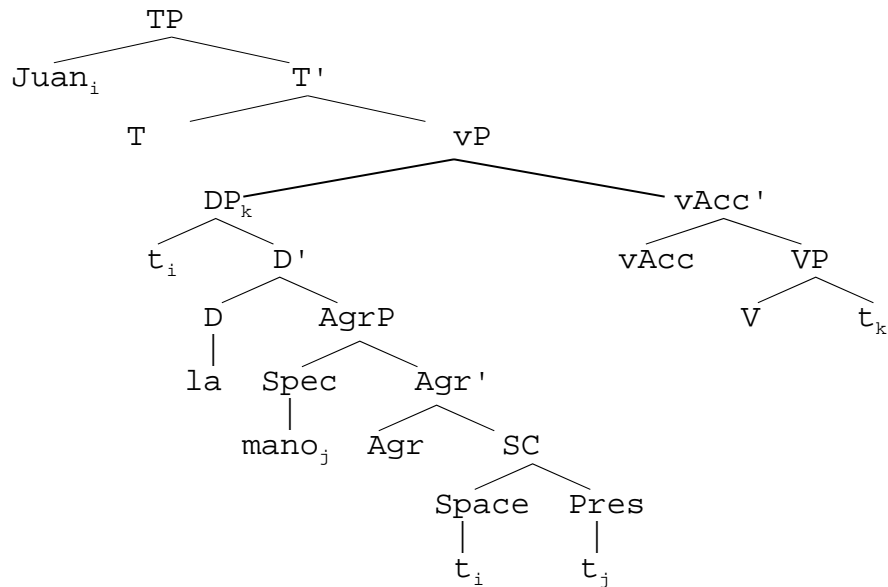

I will continue to consider here that the part *mano* does not need to move further to have its Case checked and it just shares the Case of the big DP, whose reference it has assumed.

4.2 Subject Clitic Doubling

By analogy with the analysis in Uriagereka (1999b), I will assume that sentences like (19)a involve a sort of

⁹ Norbert Hornstein (p.c.) asks whether this movement is a left branch violation. In principle, it is not if, as I interpret Uriagereka's (1999) analysis of clitic doubling, the Space moves out of the DP before the latter moves to check its Case. Of course, this raises issues of remnant movement (see Müller 1996), feature movement, etc, which I will not get into here.

clitic doubling of the subject, whose initial structure is similar to that of dative doubling sentences.

The difference is that these verbs act as unaccusatives, thus lacking an external argument. This means that one of the two nominals involved in the integral small clause has to move to [Spec,TP] to check the EPP feature of Tense, and, as a consequence, check its nominative Case as well. Given the DP-internal syntax I have been assuming, and the MLC considerations it conveys, the double in [Spec,DP] will be the chosen one to move out of the DP to the subject position.

This leaves three problems to solve: the Case for the big DP, the Case for *pro*, and the presence of *se*. If *pro* needs Case, this should not be a problem in principle. According to Uriagereka's analysis, *pro* must be able to get Case inside the DP, given that D^0 has not incorporated into a higher head.

The presence of *se* and the need for Case for the big DP might be related, then. Recall that *levantar* is a verb that obligatorily assigns accusative Case. Spanish is not an object pro-drop language, which means that an empty accusative NP cannot be licensed, presumably because of the lack of agreement features on the v-head. Then, the movement of the big DP to [Spec,vP] is not enough to allow the discharge of accusative Case.

Se is then inserted under v to allow the discharge of accusative Case. It provides the type of agreement needed by the null object to discharge accusative.

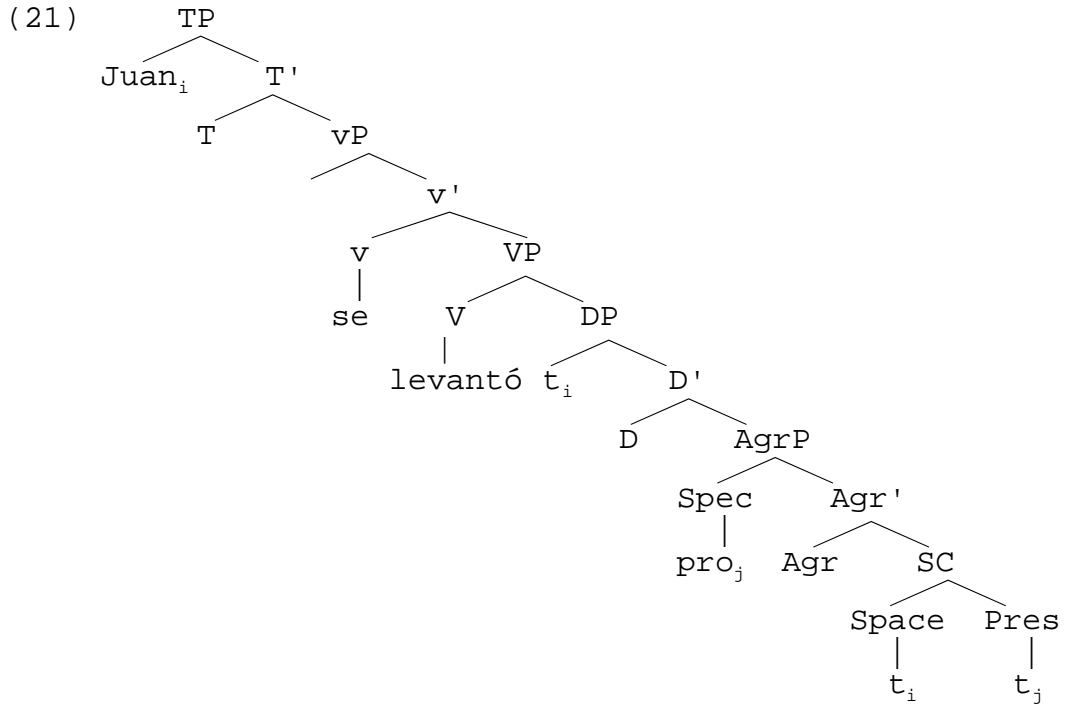

Now, we assume that the big (but phonologically empty) DP will have its Case checked at LF by moving to [Spec,vP], mediated by the presence of *se*.

4.3 Consequences of the Analysis

The process of Possessor Raising to subject position seems to be more restricted than the raising to dative. It is almost exclusively limited to the kind of verbs that Levin (1993) calls "Verbs of Gestures/Signs involving body parts." The following examples illustrate some instances of this construction:

- (22) a. Juan *mostró* los dientes.
 J showed the teeth
 'Juan showed his teeth.'
- b. Juan *levantó* una mano.
 J. lifted a hand
 'Juan raised his hand.'

The sentences in question take the surface form of a transitive sentence, where the subject is the whole and the object is the part, but I will follow Fox (1983) in

assuming that the thematic valence of the verb is reduced by one, and thus these sentences contain a single argument.

My analysis will predict all the characteristics shown by these verbs. The main reason for many of their unusual syntactic behaviors is that they are unaccusative verbs, whose internal argument is a Small Clause that is composed of the two terms of an inalienable relation.

I will now discuss the peculiar aspects of the syntactic behavior of these verbs pointed out in Levin (1993), and which apply to Spanish verbs as well as English. As I do so, I will show how the analysis proposed here accounts for these behaviors.

4.3.1 Obligatory Inalienable Reading

Levin points out that the verbs involved in this raising to subject structure require an inalienable reading between the subject and the object, when the interpretation is that of direct motion.

Syntactically, this reading is the direct result of the lexical configuration in which the two terms, the whole and its part, are generated. In this small clause, the interpretation we get is one in which the subject is a whole and the predicate is a part. Notice that the object shows a definite article, and not a possessive, but the possessive dependency is forced under this interpretation.

(22)a may have alternative readings, for instance, if Juan is a dentist who is showing a set of teeth for some purpose, but in that case the use of the definite article is subject to the typical contextual restrictions of definite descriptions. Call this the 'transitive reading'. In the 'inalienable reading', the sentence may be uttered without any explicit reference to any teeth previously in the discourse, and the only interpretation that we get is

that the teeth are Juan's.

The analysis also explains the homogeneity of the meaning of these sentences. The fact that there is a single argument of the verb predicts that these verbs should not express a causing action that is exerted by an agent upon a patient, to paraphrase Parsons (1990). Rather, the verbs describe a direct motion, in which the agent moves one of its parts. There is thus a clear difference between the two readings of (22)a described in the previous paragraph. In the transitive reading, there is an agent (Juan) and a patient (the teeth), as two separate entities which do not stand in any obvious relation of any kind. In the inalienable reading, there is no separate agent and patient. In a sense, the agent is, at the same time, acting and being acted upon, but not in a way that grants the postulation of two different thematic roles for subject and object.¹⁰

4.3.2 Obligatory Object

Another characteristic of these verbs mentioned by Levin is that the object of these constructions is obligatory. This characteristic is predicted by the analysis as well, even though through a bit of a

¹⁰ Both Norbert Hornstein and Paul Pietroski (p.c.) point out that agent-oriented adverbs are possible in these constructions:

(i) John deliberately raised his hand.

Such adverbs are usually considered to accompany sentences with external arguments, and are usually ungrammatical with unaccusatives.

Parsons (1990) also notices that these sentences follow the causative entailment found in multiple event sentences: if John raised his hand, then his hand raised. However, he still defended that there are not two separate events in these sentences, and that they form an exception to general rules in the grammar of events.

stipulation.

The verbs that participate in this construction are not typical unaccusative verbs. Following Burzio's generalization (Burzio 1986), there is a direct correlation between the ability to check accusative Case and the presence of an external argument. Thus, unaccusative verbs, which lack an external argument, should not be able to assign accusative Case. Chomsky (1995), taking on an idea by Hale and Keyser (1993), tied the two characteristics to the presence or absence of the functional head *v*. According to this proposal, *v* both assigns the external theta-role, and checks accusative Case. Transitive verbs project a *vP*, unaccusatives do not.

We have seen that the verbs of direct motion discussed in this section can assign accusative Case to the part in the inalienable relation. If, as I have proposed, these verbs do not assign an external argument, there is a violation of Burzio's Generalization. The problem created by the raising of the possessor is that in these constructions there is a single internal argument, but two nominals that need to have their Case checked. Because the possessor/whole has raised to have its Case checked against the nominative feature of *T*, the possessed/part needs to have its Case checked in a lower position.

There are several reasons to believe that the Case in question is accusative. On the one hand, it allows the use of accusative clitics:

- (23) Cuando el profesor pidió que los culpables
when the teacher asked that the guilty
levantaran la mano, Juan la levantó.
lifted the hand *J* it lifted
'When the teacher asked the guilty ones to raise
their hand, Juan raised it.'

I will assume that the mechanism that allows the checking of accusative in these instances, is the same

that allows the possessive verb *tener* 'have' to assign accusative in possessive copular constructions, which have been argued at length to be initially unaccusative (Freeze 1992, Kayne 1993, 1994, Hornstein et al. 1994, Kempchinsky 1996, Uriagereka 1996, and Ch. 1 and 3 above).

There is one further instance of an unaccusative construction that assigns accusative in Spanish, namely, existential *haber*.

(24) No los había.
not them there-were
'There weren't any.'

Thus, it seems that some unaccusative constructions in Spanish are able to assign accusative to their internal arguments, provided that nominative has been checked by an expletive, as may be the case in (24) or by a raised possessor, as is the case with *tener* 'have' and the direct motions discussed here.

It is plausible then that some unaccusative verbs can assign accusative. First, these verbs, as we have seen, usually have a transitive use as well. This means that we independently know that the lexical entries of these verbs can assign accusative Case.

Second, as we have seen, the subject clitic doubling use of these verbs in Spanish requires the presence of a clitic, *se*. *Se* has been taken to be a detransitivizing element, precisely because it appears when certain transitive verbs are used intransitively. However, I have claimed here that the reason why *se* appears is to discharge Case. Recall that the verb is still intransitive (in the sense of not assigning an external theta-role) even in examples where the part is expressed as the surface direct object of the verb. The fact that *se* does not appear in these examples means that it is not responsible for turning the verb into an intransitive, or it should appear in these instances as well.

Given that *se* only appears when the object is not phonologically realized, the most logical alternative is to think that its function is to help the verb discharge its accusative Case.

Not all unaccusative verbs, but rather only those that have a transitive lexical entry as well, can participate in this kind of structure. We can then propose that these verbs are special in the sense that they come equipped with a v-projection, but this projection assigns an external theta-role only optionally. They are exceptions to Burzio's generalization, because the v-head associated with them does not convey any thematic information. Nonetheless, their v can still check accusative Case.

Thus, we must distinguish three kinds of verbs regarding the properties of their v. First, transitives, which have a v which assigns both an external theta-role and accusative Case. Second, we have unaccusatives, which lack a v projection completely. Finally, there is a restricted set of verbs which associate with a v-head that assigns accusative Case, and has no external theta-role to assign.¹¹

Vergnaud and Zubizarreta (1992) point out that the raising to subject constructions share several characteristics with the better-studied dative inalienable construction. They treat them in a similar way, even

¹¹ Juan Uriagereka (p.c.) points out that this may have something to do with the Spanish impersonal *se* construction, exemplified in (i):

- (i) *Se habla varias lenguas en este país.*
cl-R speaks several languages in this country
'Several languages are spoken in this country.'

This construction appears to assign accusative to the object in absence of an external theta-role, like the unaccusative verbs discussed in this chapter. I leave this connection to future research.

though they acknowledge that the set of verbs that allows the structure is more restricted than the set of verbs that allow the dative construction.

Under my analysis, this is to be expected. The set of verbs that allows the dative construction is not expected to be restricted, given that most verbs in Spanish are able to assign dative Case. On the other hand, the set of verbs that allow possessor raising to subject is restricted to unaccusatives, and, among them, to a special type that allows the assignment of accusative Case.

Curiously, this typology predicts that under some circumstances, a verb may have a *v* which assigns an external theta-role, but does not check Case. This class is instantiated by the unergative verbs whose object is not syntactically realized. Thus, *v* may have an external argument, or accusative Case, or both. Under this system, Chomsky's interpretation of Burzio's generalization is in a sense preserved: if a verb does not have a *v*, then it does not have an external argument, and cannot check accusative. If a verb has a *v*, it may have an external theta-role (but does not have to), it may assign accusative (but does not have to), or both. The typology is presented in (25)

(25) Typology of verbs regarding the properties of *v*

	External argument	Accusative Case
Transitive	yes	Yes
Unaccusative	no	no
Unergative	yes	no
Direct motion	no	yes

I will thus assume that verbs of direct motion are unaccusatives in the sense that they do not have an external argument, but nonetheless have an accusative Case feature that must be discharged, either through a full DP

or through the use of a clitic like *lo* or *se*.

4.3.3 Lack of Cognate Object

These verbs lack a cognate object, according to Levin (see also Rice 1988). According to Hale and Keyser (1993), all unergative verbs are actually transitive, which means that the class of verbs that lack an internal argument really does not exist. Most unergative verbs can express their internal argument in different ways. Sometimes, it appears morphologically incorporated into the verb, as in (26)a. In other instances, unergative verbs may also appear with a cognate object, as in (26)b.

(26) a. I couldn't sleep last night.

b. I couldn't sleep a very deep sleep last night.

The reason why the direct motion verbs do not allow the presence of a cognate object is because they already have an internal argument, which is the only argument, in fact. I have assumed that both the apparent transitive version and the intransitive version start out as unaccusatives, with a single internal argument, which includes a small clause with the part and the whole. Unaccusative verbs by definition lack cognate objects, because their subject is an internal argument, and thus leaves no room in their thematic structure for another object.

Thus, the verbs that participate in the direct motion structure, being unaccusatives, lack a position in their argument structure for a cognate object.

4.3.4 Lack of Verbal Passives

Levin also cites the fact that these verbs do not allow a verbal passive construction. There is a simple reason for this fact. Recall that in Chapter 3 I discussed

the fact that the possessive verb *tener* 'have' did not allow the passive construction either:

- (27) a. Juan tiene dos hijos.
'Juan has two children.'
- b. *Dos hijos son tenidos por Juan.
'*Two children are had by Juan.'

I used this fact to support a raising analysis of the verb 'have'. I want to propose that the same reasoning stands behind the lack of a passive construction in inalienable direct motion verb sentences:

- (28) a. *Los dientes fueron mostrados (por Juan).
'The teeth were shown by Juan.'
- b. *Una mano fue levantada por Juan.
'A hand was raised by Juan.'

Again, under the intended interpretation, these sentences are ungrammatical. They can still be interpreted in a transitive sense, in which there is no inalienable relation between the body part and the agent, but not under the inalienable reading.

I will follow here the traditional analyses of passive in Jaeggli (1986) and Baker, Johnson and Roberts (1989). According to these analyses, it is crucial in the formation of passives that there is an external theta-role in the argument structure of the verb. Jaeggli takes the position that this argument is simply absorbed, but Baker et al. take the stronger position that the theta-role is actually assigned to the participial suffix on the verb.

If the verbs of direct motion discussed here lack an external theta-role, this suffices to prevent the presence of the participle in the passive construction. Because the participle never gets assigned a theta-role, the sentence results in a violation of the theta-criterion.

4.3.5 Light Verb Construction

Finally, very few of these verbs allow a construction in which a light verb takes a derived nominal as its object, such as:

(29) a. Juan hizo un giro con la cabeza.
J. made a turn with the head

b. Juan giró la cabeza.
J. turned the head

'Juan turned his head.'

(30) a. Sharon hizo un cruce de piernas.
S. made a crossing of legs

b. Sharon cruzó las piernas.
S. crossed the legs

'Sharon crossed her legs.'

In (29)a, the part appears as an adjunct. I will assume that this sentence has a radically different structure. As for (30)a, it can perfectly describe the situation in the famous scene of the movie *Basic Instinct*, but there seems to be a strong focus reading on the crossing part of the sentence. However, it is crucial in (30)a that the article does not appear next to the part, unlike the inalienable construction in (30)b. If the article appears, the sentence is ungrammatical, as shown in (31)a, unless we use the adjunct structure illustrated in (29)a, as in (31)b:

(31) a. *Sharon hizo un cruce de las piernas.
S. made a crossing of the legs

b. Sharon hizo un cruce con las piernas.
S. made a crossing with the legs

This suggests a different structure for this construction, possibly one in which there is no direct lexical relation between the possessor/whole and the part, but rather this relation is somehow mediated by the noun

that describes the action.¹²

4.4 Conclusion

In this section, I have argued that certain apparent transitive sentences in Spanish involving a subject and a direct object in a whole-part relation must be understood as being unaccusative. I have provided evidence that these sentences behave parallel to sentences with dative raised possessors, thus granting an analysis of these sentences as possessor raising to nominative. I have also shown that the analysis predicts firstly the restricted nature of the construction, and secondly the characteristics shown by the class of verbs that participate in this construction. I will now turn to a detailed analysis of several issues pertaining to possessor raising to dative in Spanish.

5. The Nature of Different Possessive Relations

5.1. Transitive vs. Intransitive Possessive Relations

One of the most invoked examples of a possessive relation is the part-whole one. This relation is also a conglomerate of different ones, as shown by Winston, Chaffin and Herrmann (1987). However, their typology of six different part-whole relations is purely descriptive. We should try to find whether there are syntactic effects that correlate with those relations.

As pointed out by Cruse (1977), part-whole relations may or may not be transitive in the mathematical sense. That is, if the relation R holds between a and b , and the same relation R holds between b and c , then relation R is transitive if it holds between a and c . Thus, (32) is an instance of a transitive relation, whereas (33) is not.

¹²Also, notice that the part appears as a bare plural *piernas* 'legs' in (30)a. This would suggest that the part

- (32) a. John has a hand.
b. The hand has a finger.
c. John has a finger.
- (33) a. The dresser has a drawer.
b. The drawer has a handle.
c. #The dresser has a handle.

In (32), the part-whole relation is transitive, because when it holds between John and his hand, and also between his hand and its finger, then it necessarily holds between John and his finger. In (33), on the other hand, the part-whole relation is not transitive. The fact that a dresser has a drawer, and that drawer has a handle does not imply that the dresser has a handle. In fact, the handle is still perceived as the drawer's and not the dresser's.

Both Cruse (1977) and Winston et al. (1987) agree that the lack of transitivity in (33) is due to a change in the nature of the part-whole relation: The drawer is an integral part of the dresser, whereas the handle is seen as an attachment to the dresser. Their hypothesis is that transitivity is preserved across similar relations only.

In this section, I will not discuss the specific pragmatic or semantic nature of transitive/non-transitive possessive relations. Nonetheless, I will explore the syntactic effects that the difference may create.

5.2. The Argument Structure of Nouns

The literature on the thematic structure of nouns has debated for a long time what the lexical requirements for this category are in terms of thematic arguments.

I must point out first that this section will not

in this instance is more predicative than it is

deal with deverbal or eventive nouns, such as the ones discussed in Chomsky (1970) or Grimshaw (1990). I assume that these nouns inherit the thematic structure from the verbs they are derived from.

I will not discuss the kinds of nouns that can be used as measures either, such as the ones discussed in Chapter 2. However, many of those nouns, when they are not being used as measures, will fall into some of the categories discussed in this chapter.

I will discuss here the possible thematic structure and requirements of nouns in the simplest sense of the category. Most nouns are able to enter into possessive relations like the ones shown at the beginning of this chapter. Furthermore, it appears that certain nouns tend to appear in these constructions with higher frequency. Some may even appear in possessive contexts only.

The purpose of this section is to classify nouns according to their argument structure, and try to give a sense of what the syntactic consequences of assuming a certain thematic structure are.

5.2.1 Classes of Nouns

It seems quite clear that nouns fit into three categories with regard to their ability to appear in possessive constructions. First, some nouns never appear without a possessor. *Son* is an example:

- (34) a. I saw John's son today.
b. *I saw a son today.

Most of these nouns are kinship terms. It has been proposed (see Keenan 1987) that these nouns have an argument position in their lexical entry. This position has to be satisfied in the same way that verbal theta-

referential, as in (30)b.

roles do.

A second class of nouns can appear with possessors, but clearly show no lexical requirement. *Book* is one such noun.

- (35) a. I saw John's book today.
b. I saw a book today.

It is generally assumed that these nouns do not have an argument position in their lexical entry, but a general process allows them to acquire a possessor if inserted in the right syntactic configuration.

There is a third class somewhere in the middle which tends to be used as parts, but can appear without overt possessors without triggering the strong ungrammaticality that kinship terms without a possessor do. Consider *leg*, which is one of these nouns.

- (36) a. I saw a leg in the room.
b. I saw a leg of the table in the room.

The question at this point is what the analysis must be for these nouns in the middle. The following sections discuss some proposals that have been put forward to try to deal with these nouns.

5.2.2 Inherently Relational Nouns

Barker (1995) proposes that the third class of nouns described in the previous section has an argument position. He defines a class of relational nouns which are inherently relational, and enter what he calls Lexical Possession relations. This class of nouns includes nouns derived from verbs as in (37)a, kinship terms like (37)b, body parts as in (37)c, generalized part-whole nouns like the one in (37)d, and arbitrary relational nouns, as shown in (37)e.

- (37) a. John's purchase.

- b. John's child.
- c. John's nose.
- d. The table's top.
- e. The woman's pen pal.

The rest of nouns do not include an argument position in their lexical entries, but they can still enter what he calls Extrinsic Possession relations.

When a noun pertaining to the Lexical Possession class is used without a possessor, Barker claims that the position has been suppressed by a process similar to the one that eliminates arguments in the case of pairs of transitive/unaccusative verbs such as the one in (38).

- (38) a. John broke the window.
- b. The window broke.

Barker's proposal requires five assumptions:

- (39) a. there is a set of nouns which lexically have an argument position.
- b. there is a set of nouns which lexically do not have an argument position.
 - c. there is a mechanism that allows suppressing an argument from a noun that lexically has an argument position.
 - d. there is a mechanism that allows adding an argument to a noun that lexically lacks an argument position.
 - e. there is a set of nouns which have an argument position but disallow argument suppression.

(39)a is intended to account for nouns like the ones in (37). These nouns have an argument position in their lexical entries, which must be filled by another noun in a possessive construction. Typically, the meaning of these nouns is relational, such as kin, part of a whole, and a quite heterogeneous and undefined set of relation-denoting nominals.

(39)b accounts for the vast majority of non-deverbal nouns, which do not denote parts, kinship relations or other relational concepts. Some of them are listed in (40).

(40) a. The book is on the table.

b. The chair is inside the house.

These nouns, which lexically do not include an argument position, do not require a possessor in the syntax.

(39)c is intended to account for the instances in which normally relational nouns appear in non-possessive constructions. Given that their argument structure includes a position for an argument, this should yield a violation of the Theta Criterion. In order to avoid this violation, Barker proposes an argument-suppressing mechanism which renders the argument possession inactive. This is what we find, according to Barker, when a relational noun is used either without a possessive, as in (41)a or with a meaning other than its relational one, as in any reading of (41)b in which John is not the children's parent (perhaps the children are part of his day-care group).

(41) a. This child is hyperactive.

b. John's children always behave very well.

(41)b is an instance of what Barker calls extrinsic possession, which basically includes anything that is not a lexical possession relation.

(39)d is formulated in order to allow possessive uses of nouns that are not relational in the lexicon. This will include relations of ownership and in general the kinds of temporary relations usually called alienable. In addition, it should also include other contextually specified relations, among them part-whole relations which involve a monadic noun, as in (42).

- (42) a. John's color.
b. This truck's seat.
c. This computer's switch.

Finally, (39)e accounts for a set of nouns which apparently never appear without a possessor. Most of these nouns are kinship terms, but some of them may express other kinds of relations, as in (43).

- (43) a. *A son came to the party.
b. *?The birthday was a lot of fun.

I believe that this account, while descriptively accurate, requires too many assumptions. It divides nouns into three classes, and not just two, because the Lexical Possession nouns must be divided between those that allow argument suppression and those that do not. The solution, thus, does not reduce the complexity of the problem.

Besides, Barker's account also requires two mechanisms for dealing with arguments: one is the argument suppression, and the other is the argument insertion.

Complicated accounts such as this have been criticized by Uriagereka (1997), who takes the extreme view that no nouns ever have a lexical argument position. Rather, he proposes a general operation by which any two nouns can engage in a possessive relation. This relation is the Integral, which we saw in previous chapters, and can generally apply to any noun. Uriagereka explicitly rejects that even kinship terms have an argument position in their lexical entry, justifying this by saying that, if all nouns can enter into Integral relations, then all nouns might be considered relational. He rather takes the view that no noun is lexically relational.

In the remainder of this chapter I will argue that a view in between may be most adequate, given the evidence gathered from the process of Possessor Raising in Spanish.

6. A Case-Study: Possessor Raising in Spanish and

Different Possessive Relations

In this section, I will argue that the set of nouns which are lexically relational, and thus have an argument position in their lexical entries is severely restricted. Several syntactic arguments to identify this set of nouns will be given. Given that these nouns will never appear without an argument, no argument suppression mechanism will be invoked.

I will also argue that the rest of nouns lack an argument position, but a mechanism of argument insertion will be readily available to all of them. this mechanism is similar to the one deployed in Chapters 2 and 3, and consists of a small clause (henceforth SC) where the possessed noun acts as the Presentation (Predicate) for a conceptual Space (the Subject).

The analysis will thus be simpler than the one by Barker (1995) discussed in the previous section, while at the same time preserving its virtues. The analysis presented here will also account for the fact that some nouns seem to require an argument position, contra Uriagereka (1997).

I will follow Hornstein et al. (1994), Uriagereka (1995,1997) in assuming that part-whole relations between two nouns are established in a small clause. The whole is the subject of the SC, what I called Space in Chapter 2, and the part is the predicate of the SC, or Presentation, in the terms used above. The way in which this relation is lexically established is the same as the container-content relation we saw in Chapter 2. The SC is represented in (44).

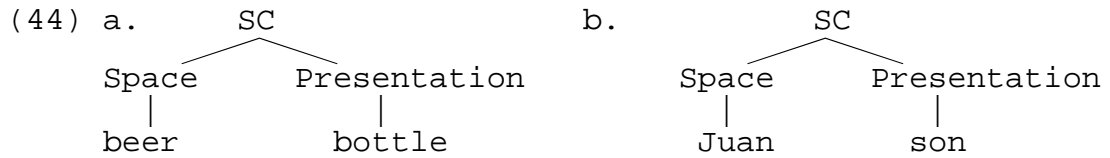

The parallel between the two structures continues at the functional level as well. The possessive SC is also dominated by two functional projections, which I called DP and AgrP, as shown in (45).

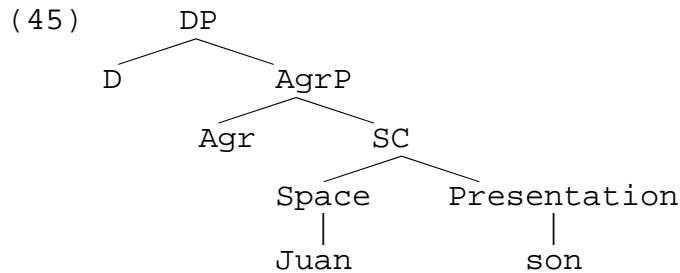

AgrP is headed by a functional element Agr, which checks agreement features with the element that moves into its specifier. In addition, AgrP has the semantic import of determining the reference of the whole expression.



I will also assume with Uriagereka (1999b) that there is a second functional projection, called DP, where a contextual confinement feature [c] is checked. The movement through this position determines the interpretation of the possessor as contextually related to the possessed in a way that will be made clear in the following examples. I will also assume that this movement triggers the interpretation of the possessor as a participant in the event of the verb, in the sense of Bleam (1999).

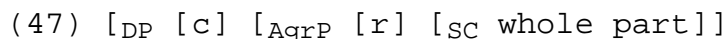

It is also crucial to this analysis that the whole structure may be applied recursively, so that a whole DP can be used as the subject of a higher SC, as in (48).

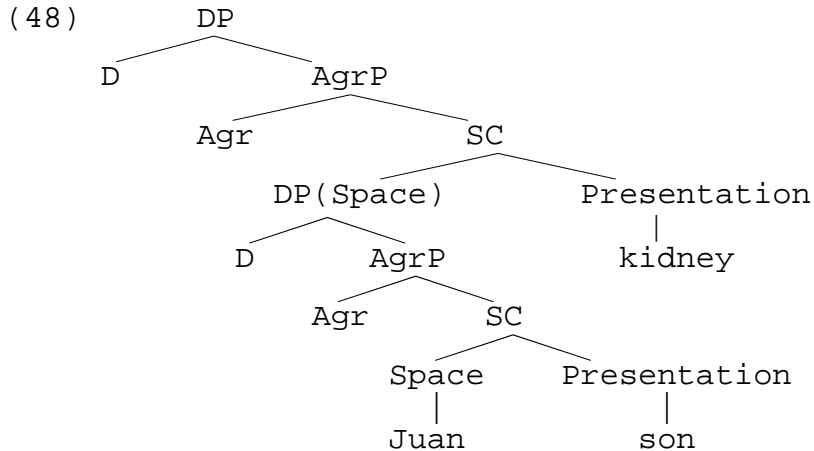

Furthermore, it is essential that the element that checked the [r] feature in the lower DP is the one that enters the higher SC as the conceptual Space to be presented by the predicate. We saw how this played a role in the determination of certain facts about Spanish measure phrases such as the one in (49).

(49) ?un vaso de botella de cerveza.
 a glass of bottle of beer

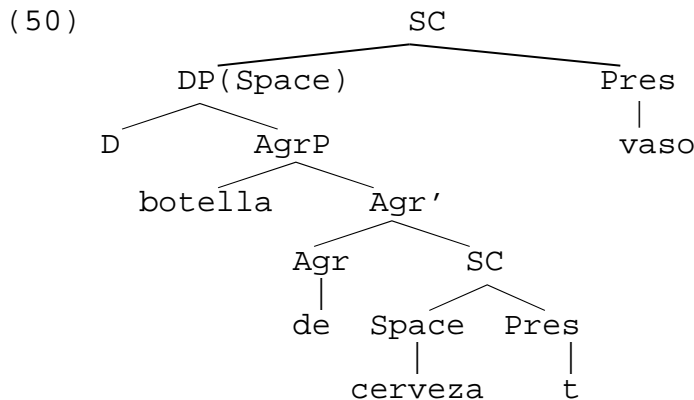

The oddity of the example (49) is shown in the structure in (50). When the Presentation/Container *botella* moves to check the referential feature of *Agr*, it takes over the selectional features of the whole DP at the higher level. When the expression becomes the subject of the next SC, the measure applies to bottle and not to beer, with an uninterpretable result.

6.1 Kinship

The first possessive relation I will look at will be that of kinship. I take this type of noun to be the typical example of a noun that requires an argument in its syntax, as argued among others by Keenan (1987). Thus, the lexical entries for kinship nouns such as *son* will include a variable position for an argument, as in (51).

(51) *son* (x)

This explains why nouns like this form ungrammatical sentences when no possessor is expressed overtly:

- (52) a. *A son came into the room.
b. John's son came into the room.
c. John has a son.
d. Le mataron un hijo a Juan en la guerra.
cl killed-they a son to Juan in the war
'A son of Juan was killed in the war.'

As we can see in these examples, the possessive relation may be expressed in different ways, as long as the argument position of *son* is saturated in the syntax. In (52)a, no possessor appears, and the sentence is ungrammatical, presumably because of a theta-criterion violation. In (52)b, the possessor is part of the same DP as the kinship noun. In (52)c, the possessor has raised to subject position, if we are to assume the analysis put forth by Kayne (1994), and followed by others, such as Hornstein et al (1994) or Español-Echevarría (1995). Finally, in (52)d, we see another kind of possessor raising, the one where the possessed noun is expressed as a direct object, and the possessor appears as the indirect object.

As is clear from the data above, it seems that the surface structure in which the possessor and the possessed appear is irrelevant to the grammaticality of the

sentence. Rather, the key resides at the lexical level, where theta-relations are established. In all the grammatical examples in (52), there is a SC whose predicate is *son*, and which contains a subject that satisfies the thematic requirement of the relational noun.

In (52)b, the possessed moves to the referential position and the possessor moves to the [Spec,DP].¹³

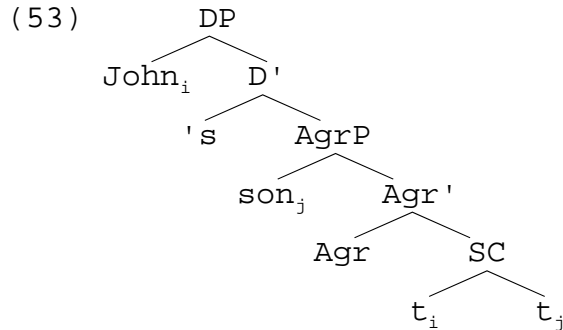

In (52)c, the possessor moves out of the SC and its functional layers to become the subject of the sentence. As pointed out by Kayne (1993), this movement is allowed by the incorporation of the D⁰ into the verb, which turns BE into *have*, as shown in (54).

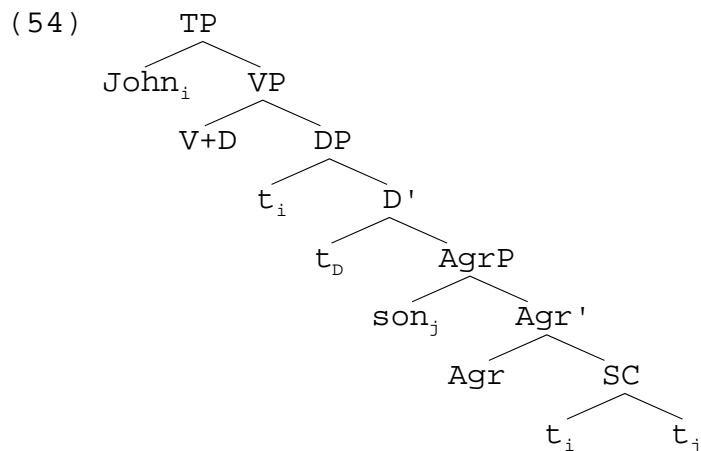

Finally, in (52)d, the possessor moves to a

¹³ This structure assumes that phonologically overt DPs can have their Case checked in [Spec,DP] in English. This may well be the reason that English shows DP-internal prenominal possessors, whereas Spanish never does.

projection of V, where it receives dative Case from the verb. Following the analysis in Uriagereka (1999b), I will assume that the clitic in Spanish allows the checking of dative in [Spec,VP].

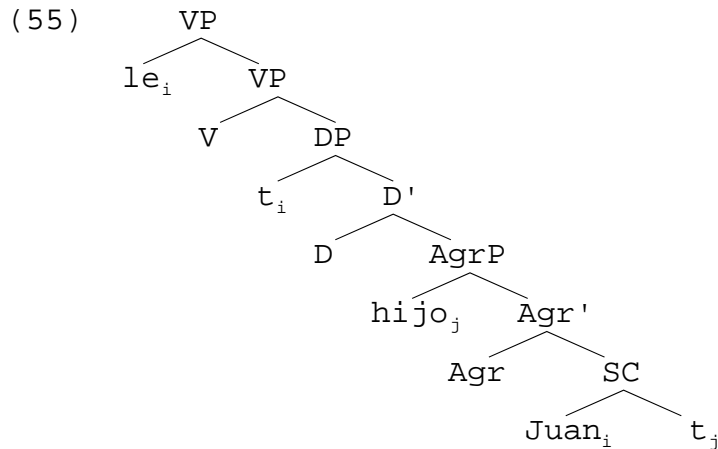

The thematic requirement imposed by the kinship noun becomes especially evident in instances in which it does not enter a lexical relation. Consider the contrast in (56).

- (56) a. *Le han quitado un riñón del hijo
 cl-D have-they removed a kidney of-the son
 a Juan
 to J
- b. Le han quitado un riñón al hijo
 cl-D have-they removed a kidney to-the son
 de Juan
 of J

'Juan's son has had a kidney removed.'

In both cases, there is a kinship relation between Juan and his son, and an inalienable relation intended to be between Juan's son and his kidney. In the grammatical (56)b, the raised possessor is the kinship relation *hijo de Juan*, whose referent is not Juan, but his son. On the other hand, in the ungrammatical (56)a, the raised possessor is Juan, which acts as a possessor for his son's kidney.

Notice what the structure of the (56)a is:

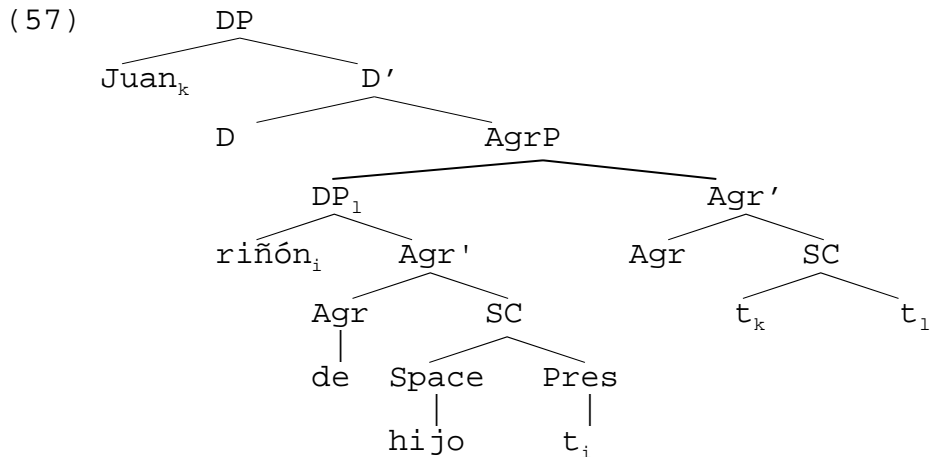

The ungrammaticality of the sentence can have several sources. First, in (57) *Juan* moves to [Spec,DP], the position where presumably contextual features are checked. This means that it will be the raised possessor and thus is interpreted as the participant in the event, or as contextualized to its possessed, the kidney in this case, at the time of the event. But the kidney has already been assigned a possessor, namely the lower noun *hijo* 'son'.

This conflict could be understood as leading to a potential thematic violation. The kidney, which has been already used as a predicate for the lower whole *hijo* 'son', cannot be a predicate for *Juan* as well. However, in a later section of this chapter, I will show other instances in which the same noun can be a part/predicate for two different wholes, and the sentence is grammatical nonetheless. I will thus discard the notion that the conflict between the part and the two wholes is a thematic violation, but the semantic conflict persists, because of the nature of the relationships under consideration: it is still a fact that the same kidney cannot be part of two different people. We can understand this conflict then as a problem of interpretability, the kind of pragmatic violation that Chomsky (1995) calls gibberish.

A second alternative is that the kinship noun *hijo* 'son' is the subject of a SC but it never occupies a

predicate position where its thematic role is saturated. Because the predicate of the lower SC *riñón* 'kidney' has checked the reference of the expression at that point of the derivation, it picks up the semantic features of the whole DP at the next higher SC, and *hijo* is left out without an argument, as shown in the small clause structure:

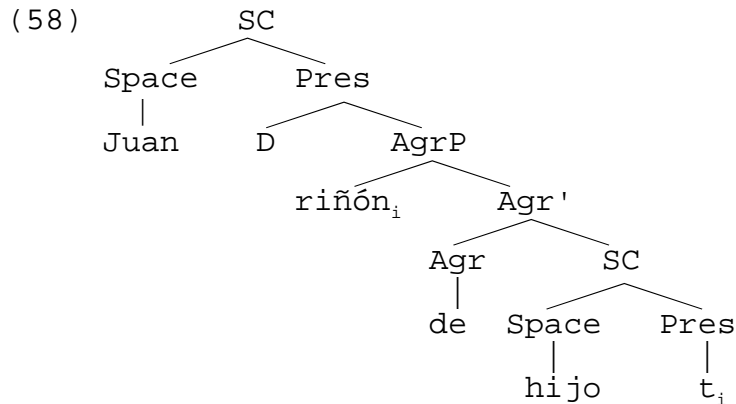

If we believe that kinship terms have an argument position, then the ungrammaticality of the structure in (58) is explained as a thematic violation, similar to a verb not discharging one of its theta-roles.

The contrast with the grammatical (56)b becomes readily apparent when we draw the structure and see that the kinship term *hijo* in this sentence is acting as a predicate for the subject *Juan* in the lower SC, and thus having its argument position saturated.

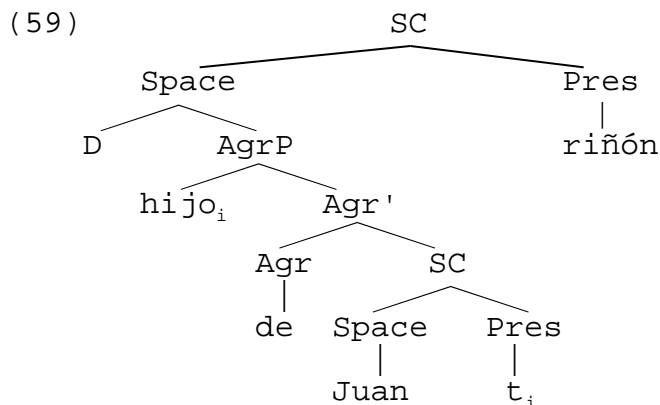

In this instance, the lexical relations are

established in the following manner. First, *hijo* 'son' is a predicate for Juan, thus, its lexical requirement to have an argument is satisfied. Next, *hijo* moves to the referential position of the lower AgrP, becoming the referent of the expression. When the whole DP becomes the subject of a higher SC, it enters a whole-part relation with the noun *riñón* 'kidney'. Given that we know that a part of a part-whole relation can be a whole in another, this does not create any thematic or pragmatic conflicts, thus yielding a grammatical structure.

At the same time, the explanation in terms of affectedness/participation can also find the relevant contrast. In the final structure, shown below under (60), the DP with the kinship relation *hijo de Juan* 'Juan's son' becomes the raised possessor, after checking the [c] feature in [Spec,DP]. Since the referent of this DP is Juan's son, it can be understood as the event participant in the removal of the kidney, as is the intended interpretation.

(60)

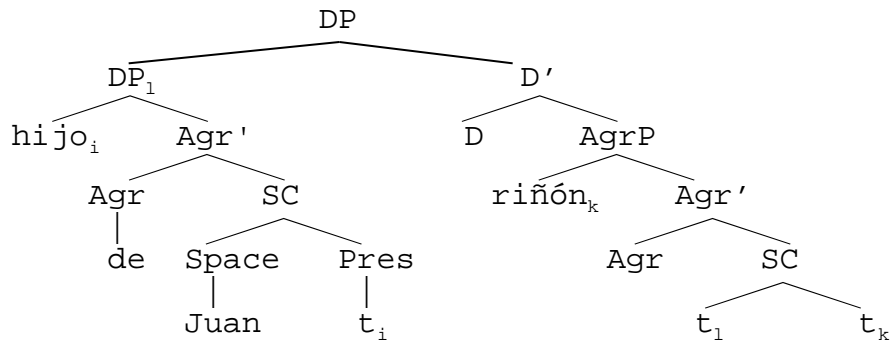

At this point, I feel no compelling reason to prefer one explanation over the other. On the one hand, the fact that possessor-less kinship terms tend to lead to serious deviation seems to support the lexical analysis. On the other hand, we will see that the affectedness/event participation analysis will be independently needed in other kinds of possession. This is the topic of the following sections.

6.2 Transitive Part-Whole

Exactly the opposite pattern to the one that we discovered with the kinship relation is found with transitive part-whole relations. Recall that a transitive part-whole relation is defined in mathematical terms: if R holds between A and B, and R also holds of B and C, then it must also hold of A and C.

Two examples of such relation are presented in (61) and (62), one involving an animate possessor and another with an inanimate one.

- (61) a. Juan tiene una mano.
b. La mano tiene un dedo.
c. Juan tiene un dedo.
- (62) a. El coche tiene motor.
b. El motor tiene bujías.
c. El coche tiene bujías.

What defines the relations in (61) and (62) as transitive is the fact that the combination of the truth of the a- and b-examples implies the truth of the c-examples.

When we try to perform possessor raising out of a possessive DP whose possessed element is a possessive DP itself, the results are as follows:

- (63) a. Le han quitado un dedo de la mano
cl-D have-they removed a finger of the hand
a Juan.
to J
'Juan had a finger removed from his hand.'
- b. #Le han quitado un dedo a la mano
cl-D have-they removed a finger to the hand
de Juan.
of J
'A finger was removed from Juan's hand.'

The interpretations of these two examples are radically different. (63)a describes a situation in which

a finger has been removed from Juan's hand, as it was attached to his body. In the second example, we get a reading in which the hand has been detached from Juan's body, but crucially the reading in which the hand is still inalienably related to, and part of, Juan's body is not available in (63)b.

The same interpretative intuitions are triggered by an example with an inanimate possessor:

- (64) a. Le he quitado las bujías del motor
cl-D have-I removed the sparkplugs of-the engine
al coche.
to-the car
'I removed the sparkplugs from the car's engine.'
- b. #Le he quitado las bujías al motor
cl-D have-I removed the sparkplugs to-the engine
del coche.
of-the car
'I removed the sparkplugs from the car's engine.'

Whereas (64)a forces an interpretation under which the engine is still a part of the car, (64)b only admits an interpretation in which the engine has been taken out of the car.

There may be an issue between a sentence like (64)b and the availability of a sentence like the following:

- (65) Le he quitado las bujías al coche.
cl-D have-I removed the sparkplugs to-the car
'I have removed the sparkplugs from the car.'

The availability of this sentence seems to imply that the highest whole in the syntactic context is always preferred as a dative in these instances.

Let us see what may have triggered these interpretations.

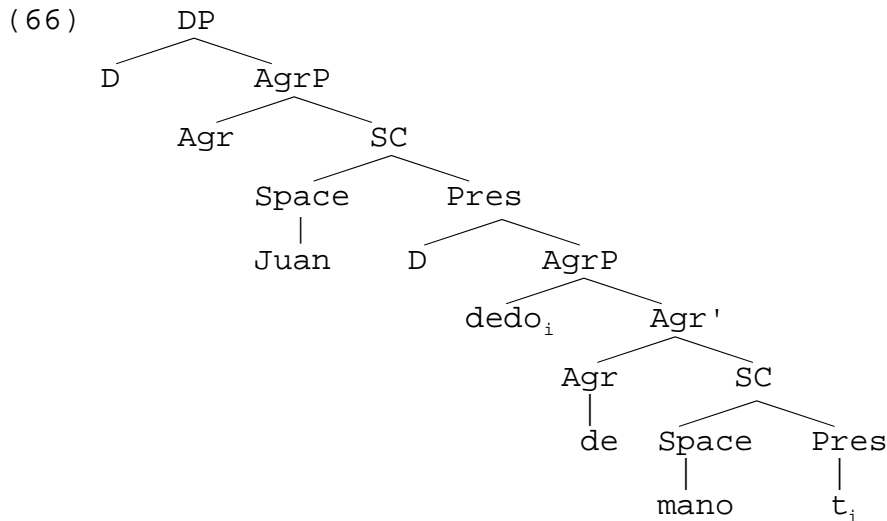

In (66), the first part-whole relation is established lexically between the finger and the hand. The part *dedo* 'finger' becomes the referent, by virtue of its movement to [Spec,AgrP], and thus will be the predicate at the higher SC.

In the second SC, a new part-whole relation is established, this time between the finger and Juan. The relation established between the latter two allows an inalienable reading of the finger and the person, which implies the existence of the relation between Juan and the hand as well. However, notice that this relation is not established lexically, but rather inferred pragmatically, as a consequence of the fact that the relation of possession is transitive in this case.

The difference between the example in this case, and the one seen with kinship terms is the transitivity of the relation between Juan, the hand and the finger. What these examples show is that a noun can serve as a part for two different wholes, as long as these two wholes stand in a part-whole relation themselves, and the two relations are transitive. This is the reason why I discarded a thematic explanation for the ungrammaticality of the kinship example (56)a in the previous section, since nothing in principle prevents the same noun from being a predicate

for two different nouns. This leaves us out with the lexical and the pragmatic explanations for the kinship behavior, as I pointed out.

Consider now what the final structure for (63)a is. It is crucial that the raised possessor is the affected participant in the event, in this case, Juan, as seen in (67).

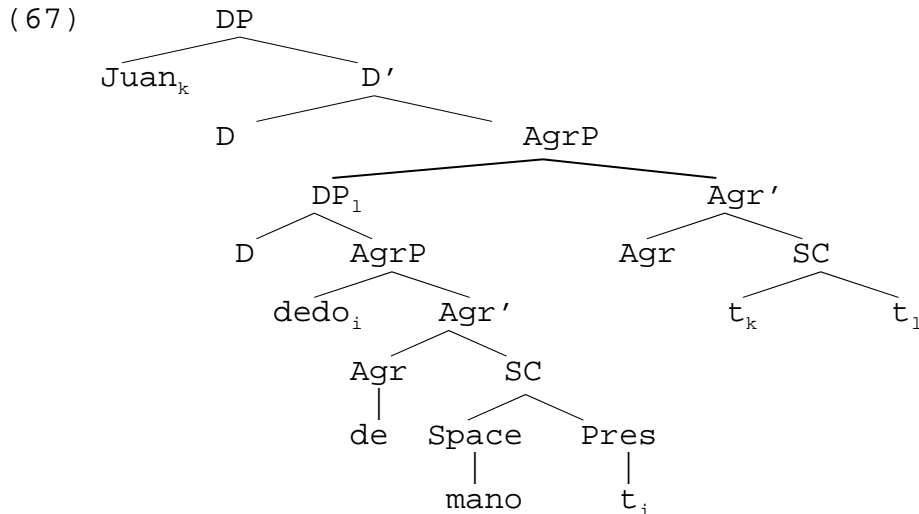

The fact that *Juan* raises to [Spec,DP] is crucial in this instance. By doing so, it becomes the affected possessor, and participates directly in the event. The finger is then contextualized directly to him, and the inalienable relation sealed.

Let us analyze now the ungrammatical example (63)a, whose initial structure is given in (68). The difference between (68) and (66) is that in the former there is no relation established between the lowest part and the highest whole. The relations established are the one between the hand and the finger, and the one between the hand a Juan. But, crucially the relation that is not established is the one between the finger and Juan.

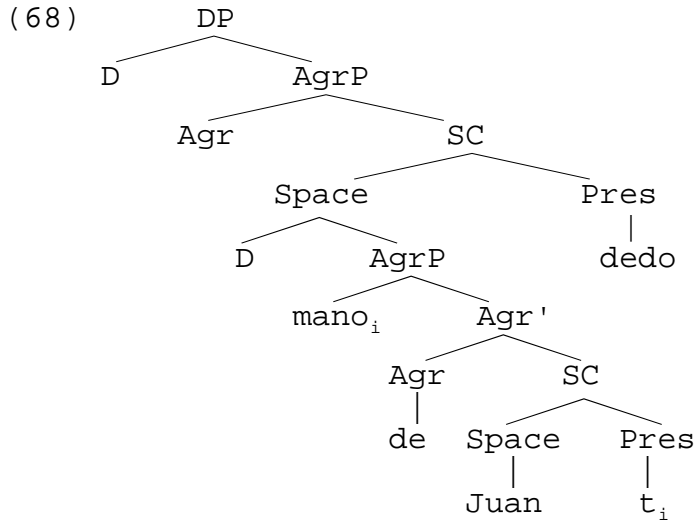

As a result of this structure, when the two terms of the higher SC move to the higher functional projections, the structure will be as in (69).

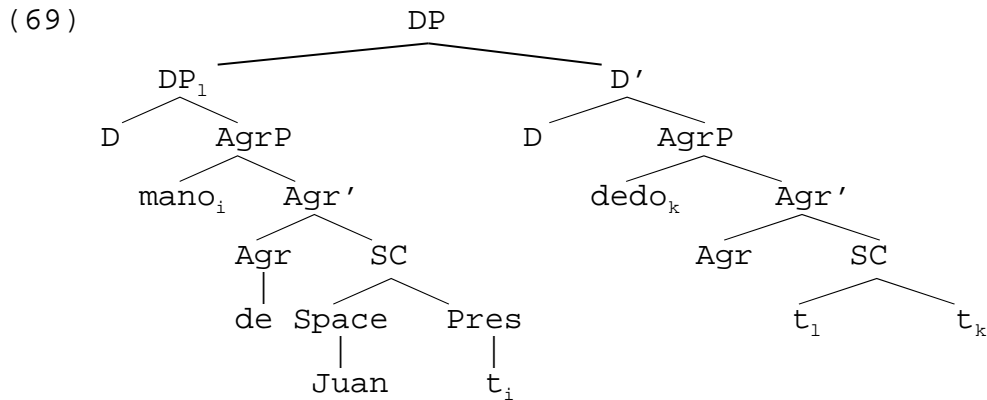

Notice that the raised possessor now is the whole DP *mano de Juan* 'Juan's hand', whose referent is the hand. This means that the affected/participant in the event is not Juan, but his hand. Here the inalienability of the relation between Juan and the finger is not established, and there is only an arbitrary relation between the hand and Juan. Crucially, because *Juan* is never in any [Spec,DP], or equivalently, marked dative, it is never contextualized as taking part in the event directly.

This once again supports the view defended in Uriagereka (1999b) that affectedness is a property defined in the position of [Spec,DP], which also happens to be the

escape hatch out of the DP on the way to the dative-checking position.

6.3 Intransitive Part-Whole

In this section I will consider the behavior of intransitive part-whole relations with respect to possessor raising to dative in Spanish. An intransitive part-whole relation is shown in (70).

- (70) a. The dresser has a drawer.
b. The drawer has a handle.
c. The dresser has a handle.

This relation is not transitive, because the truth of (70)a and (70)b does not imply the truth of (70)c. According to the study in Winston et al. (1987), we find intransitive relations when the nature of the relation between the implicated parts and wholes changes from one to the other. So, according to them, the relation established in (70)a between the dresser and the drawer is one of integral part, whereas the one established between the drawer and the handle in (70)b is one of attachment. When we try to apply the relation between the handle and the dresser we find a conflict. The handle may be an attachment to the dresser, but then it would not be an attachment to the drawer anymore.

Now consider how the non-transitive relation fares in the Possessor Raising examples.

- (71) a. Le he quitado un tirador al cajón
cl-D have-I removed a handle to-the drawer
del tocador.
of-the dresser
b. Le he quitado un tirador del cajón
cl-D have-I removed a handle of-the drawer
al tocador.
to-the dresser

'I have removed a handle from the dresser's drawer.'

It is remarkable that the both (71)a and (71)b are grammatical, since in the previous two instances we saw that only one of the two possibilities yielded a grammatical sentence. There is something special then that separates non-transitive relations from the kinship and transitive part-whole relations seen in the previous sections.

Looking at (71)a, we can see the way the lexical relations are established. The relevant structure is presented in (72). The lower SC has *cajón* 'drawer' acting as a part for the whole *tocador* 'dresser', and moving to [Spec,AgrP], where it becomes the referent of the expression. Now the drawer will be the whole at the higher SC, where *tirador* 'handle' will be the part. All is fine, as both part-whole relations are granted.

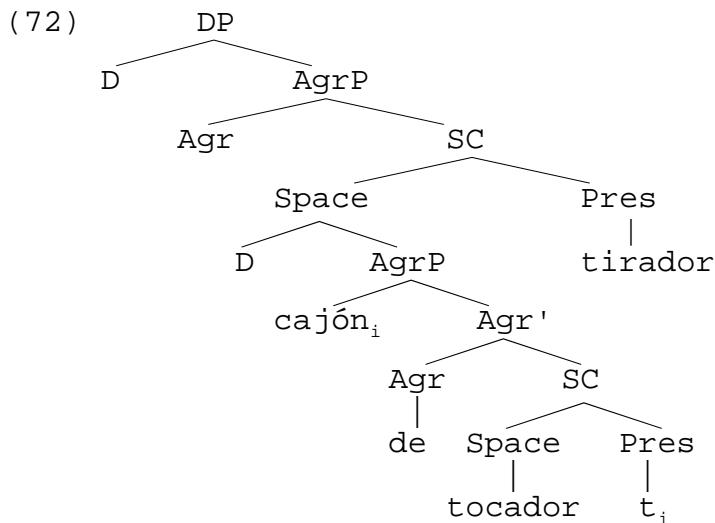

Notice that there is no direct lexical part-whole relation between the dresser and the handle in (72), but that is expected, because there is no part-whole relation between them, given the intransitivity of the pair of relations.

The final structure of (71)a, once the two members of the higher SC have moved to their corresponding functional projections, is as in (73).

(73)

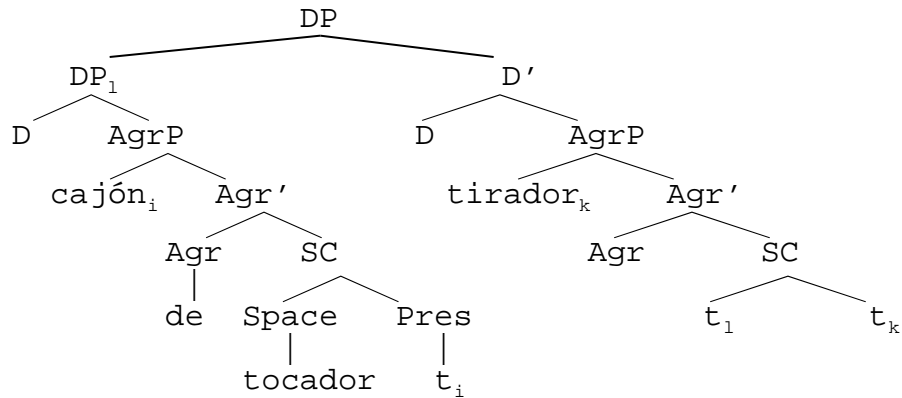

In this instance, the whole lower DP *cajón del tocador* 'dresser's handle' becomes the affected/event participant possessor. Even though there is no implication that the dresser is a participant in the event, the inalienable reading of its relation to the drawer is still allowed, that is, the drawer may be attached to the dresser or not.

What is not expected is that the alternative structure (71)b is grammatical as well. Let us see what the derivation for this example is, starting with the lexico-conceptual level, shown in (74). The lower SC contains *tirador* 'handle' acting as a part for *cajón* 'drawer'. The part becomes the referent of the lower DP by moving to [Spec,AgrP], a move which also implies that the handle will be the part at the higher SC, where it is applied to the new Space *tocador* 'dresser'.

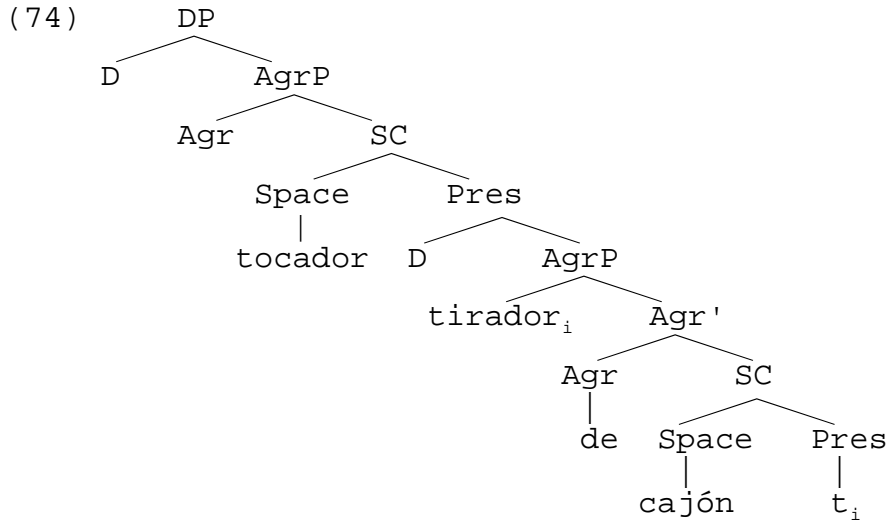

The final structure, after all movements internal to the big DP have been performed, is given in (75).

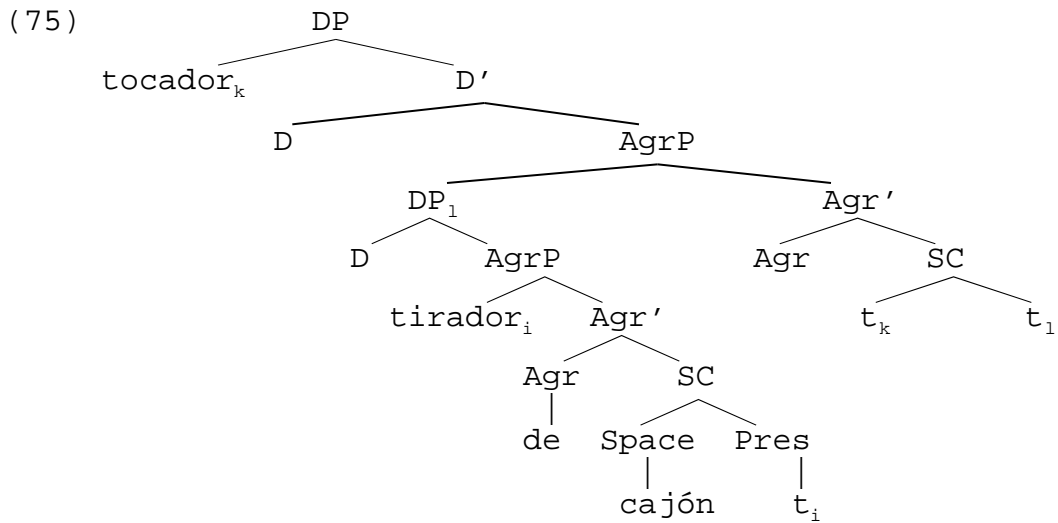

What happens in this instance is that the participant in the event is the dresser, by virtue of the movement of *tocador* to the higher [Spec,DP] position. This forces an interpretation where there is an inalienable relation between the dresser and the handle, without the direct mediation of the drawer.

Given that there is no direct part-whole relation between the handle and the dresser, and that this relation is not implied by the establishment of the other two, it seems unexpected that the mediation of the drawer is not needed. This rather means that the intransitivity of the

relation is superseded in this instance, and it can be understood as a three-way part-whole relation.

The peculiarity of the intransitivity relation is not that it can be treated as a transitive relation, but rather, that it does not have to be. The possessive raising structure has enough flexibility to be extended to instances in which the relation is not directly inalienable. When the relation between two terms is not established lexically or intentionally, as in (71)a, no ungrammaticality results, and the relation can still be inferred pragmatically. In the case of transitive relations, we saw that the part-whole relation between the highest whole and the lowest part must be established in the syntax. In the case of intransitive relations, the relation can also be established outside of syntax, for reasons that I do not understand at this point.

6.4 Alienable Relations

Next I will discuss examples in which there is a part-whole relation applied to an object which enters an alienable relation. In general, possessor raising in Spanish applies quite freely with alienable possessors.

- (76) a. Le he robado el boli a Juan.
cl-D have-I stolen the pen to J
'I have stolen Juan's pen.'
- b. Me están arreglando el coche.
Me-D are-they repairing the car
'They are repairing my car.'

When the part whole relation is applied to an alienably possessed object, the paradigm is the same as with intransitive part-whole relations:

- (77) a. Le he quitado una pata de la silla a Juan
 cl-D have-I removed a leg of the chair to J
- b. Le he quitado una pata a la silla de Juan
 cl-D have-I removed a leg to the chair of J

'I have removed a leg from Juan's chair.'

The part-whole relation between the chair and the leg is unproblematic, since in both sentences it is established lexically in a small clause. The difference is that Juan is lexically related to the leg in one case and to the chair in the other. In (77)a, Juan is the affected/participant in the event, by virtue of moving to the higher [Spec,DP], as shown in (78).

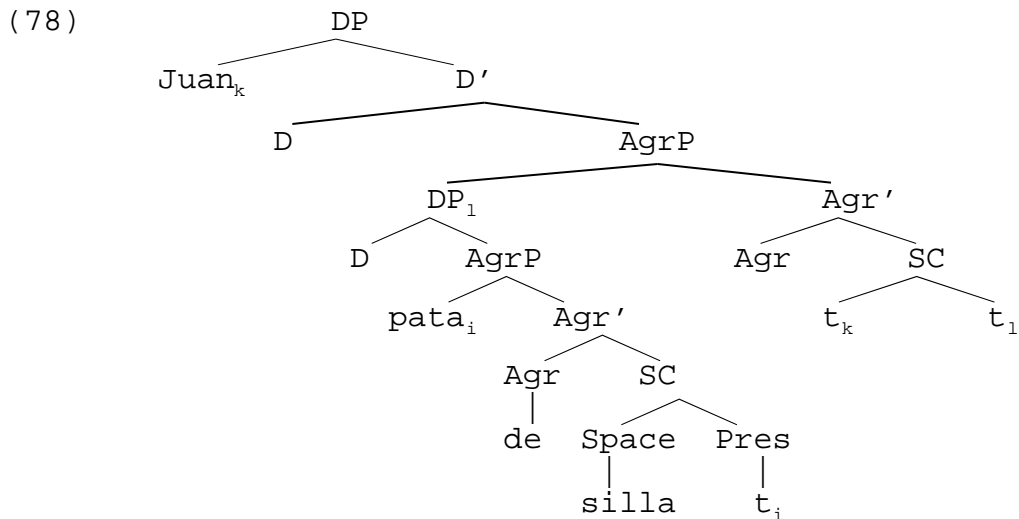

It does not matter that there is no lexical relation established between Juan and the chair, since the chair is not an inalienable part of him, and thus it is not expected that there is a direct contextualization between the two. By establishing an alienable relation between Juan and the part *pata* 'leg', that seems to imply that the whole *silla* 'chair' is of its property as well.

The final structure for (77)b is shown in (79).

(79)

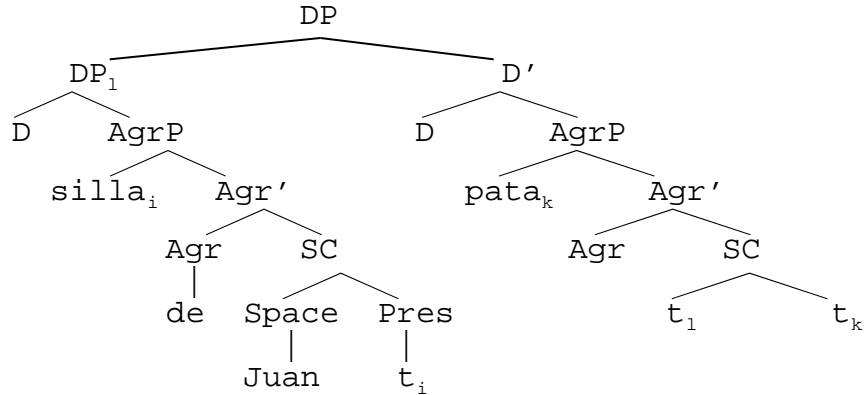

The alienable relation between the chair and Juan is established lexically, as is the part-whole relation between the chair and the leg. In this instance, the affected/participant in the event is the lower DP *silla de Juan* 'Juan's chair'. The reading is straight forward, as the two relevant relations are established lexically and nothing has to be inferred.

6.5 Conclusion

There seems to be a hierarchy of restrictions which starts with kinship relations, being the most restricted, continues with transitive part-whole, then intransitive part-whole, and finally, the least restricted seems to be the alienable relation.

Kinship relations require that a relation is established lexically, by inserting a subject that fills its argument position. In transitive part-whole relations, we have a part that can belong to two different wholes, but there has to be a direct contextualization between the highest whole and the lowest part, in order to get an inalienable interpretation. When the relations are not transitive, or are alienable, the contextualization needs not be established syntactically, and can be inferred pragmatically, thus yielding a less restricted set of grammatical structures.

7 Conclusion

This chapter has tried to give a unified account of a series of constructions which involve the raising of a possessor out of the DP where it is originally merged. I have argued that these constructions all start in an integral small clause, and that the possessor must raise to have its Case checked, because the value of its Case cannot be checked internally to the DP. Possessor raising also correlates with movement through [Spec,DP], yielding a restricted set of interpretations associated with this position, and having to do with animacy, participation in the event and affectedness.

I have argued that possessor raising in Spanish involves two different landing sites for the raised possessor. First, some possessors raise to subject, thus checking nominative. This analysis of direct motion verbs implies that the externally apparent transitive verbs are in fact unaccusatives, and that these unaccusative verbs can assign accusative Case to the possessed object. Second, other possessors raise to check dative. This kind of possessor raising is a lot more productive, and happens across an array of different possessive relations, which are studied in detail in this chapter. Both kinds of possessor raising share parallelisms with double object constructions, which follows from the fact that doubles and possessors are generated in similar integral small clauses.

CHAPTER 5

TOWARDS A UNIVERSAL ACCOUNT OF POSSESSOR RAISING

This chapter explores a syntactic process known as Possessor Raising or, as it is usually called in the Relational Grammar (RG) tradition, Possessor Ascension. Possessor Raising can be defined as the transformation that takes the D-structure possessor of a direct object in the sentence and assigns to it a surface grammatical relation (GR) to the verb of the sentence.

With the elimination of the levels of D-structure and S-structure from the grammar in the Minimalist Program (MP), the concept of GR must be revised. D-structure GRs are understood as lexical configurations at the point at which elements are merged in the syntactic structure. Following Chomsky (1995), these configurations correlate with lexical dependencies such as selectional restrictions and assignment of theta-roles. On the other hand, S-structure GRs are thought of as checking relations between functional heads and elements moved to check the features of those heads. From this definition it follows that the domains of theta-assignment and Case-checking/agreement are dissociated.

To illustrate this point, consider (1).

(1) Everybody believes Homer to like doughnuts.

In (1), *Homer* is understood to be the subject of the embedded sentence. This is why (1) is a good paraphrase of (2).

(2) Everybody believes that Homer likes doughnuts.

However, *Homer* in (1) also appears to be the object of *believe* in the matrix clause, as shown by its ability to passivize or the fact that it can be substituted for with an object pronoun:

(3) a. Homer is believed to like doughnuts (by everybody).

b. Everybody believes him to like doughnuts.

In the RG tradition, a sentence like (1) is analyzed as an ascension: the subject of the embedded clause raises to the object position in the matrix. The Standard Theory has dealt with sentences like (1) in different ways, but always underscoring the fact that the embedded subject receives/checks Case from the matrix verb. The Exceptional Case Marking (ECM) analysis of Government and Binding (GB) assumed that the verb assigns Case to the subject of the embedded clause by governing the subject's position inside its own clause. The MP resuscitated the old raising analysis, making the embedded subject raise to a projection in the matrix clause to check Case with the matrix verb. This movement has been proposed to be both overt (Johnson 1991, Koizumi 1993, Lasnik and Saito 1993) and covert (Chomsky 1995).

The motivation for the movement of the embedded subject is usually blamed on some deficiency associated with infinitival clauses. The GB-MP tradition understands this deficiency to be the inability of non-finite tense to assign/check nominative Case. Thus, *Homer* in (1) is merged as the subject of *like*, and receives a theta-role in that configuration. This is its initial GR. Since Case is a [-interpretable] feature at LF (Chomsky 1995), it must be checked and eliminated in the syntactic component. Given that the checking of features belongs to the domain of functional projections, *Homer* has to move from the lexical configuration where it has been merged to a functional head that can check accusative. Given that the matrix verb *believe* (or maybe a functional projection dominating it, such as Agr₀ or *v*) also contains an uninterpretable Case feature, there are in fact two uninterpretable features that could drive the movement of the object, depending on whether we consider the operation to be Move or Attract. Earlier versions of the MP (Chomsky 1995:ch. 3) propose

the principle Greed, by which an element only moves to satisfy its own requirements. Under Greed, then, it is the object's Case feature that triggers the movement. However, later versions of the MP (Chomsky 1995: ch. 4) subordinate movement to the operation Attract: it is the verb's Case feature that attracts the object and thus forces the movement.

The proposal that Case drives movement of DPs leaves two questions unanswered, though: i) what is Case; and ii) why does Case force movement. I believe that the two questions are very closely related. Intuitively, Case marks the surface GR of an argument that has been displaced from its base position. Grammars tend to have unambiguous derivations that allow speakers to relate elements to their base positions, such as the Minimal Link Condition (MLC), which explains why (4) can be generated from the initial GRs in (5)a but not the ones in (5)b.

(4) He saw her.

(5) a. [_{VP} he [_S saw her]]

b. [_{VP} her [saw he]]

Assuming that in (4) both the subject and the object have been displaced from their base positions and sit in the Specs of functional projections, the MLC makes sure that the object can never move over the subject to reach the [Spec,TP] position where nominative Case is checked. Therefore, if the grammar conspires to relate Cases and merge positions unambiguously, Case allows us to identify the position where arguments are generated.

But this explanation of the facts still does not provide an answer for the deeper second question, which is why DPs have to move at all. The reasons may be related to edge-effects or maybe even to acquisition. If children need as much evidence as possible in a limited domain (as proposed by Lightfoot 1991), then it makes sense that DPs

tend to move to the left periphery of the sentence, especially if the phrase structure theory outlined in Kayne (1995) is on the right track. If asymmetric c-command and linear order are directly related, then the domain of degree-zero learnability proposed by Lightfoot corresponds to the highest positions of the tree. These positions are the targets of all syntactic movement.

Following this line of reasoning, we can understand Possessor Raising as a process by which possessors move to more prominent positions in the sentence. Ever since Chomsky (1977) introduced the notion of Subjacency, clauses and DPs have been understood to be opaque domains to movement relations—more technically, bounding nodes. If Lightfoot is right, it makes sense to think that elements tend to 'get out' of categories that are potentially bounding nodes to make themselves more accessible to Primary Linguistic Data (PLD). However, as is the case with movement out of clauses, a certain level of parameterization is expected out of DPs. As we will see, not every language exploits these possibilities to the same extent.

1. Possessor Raising

1.1. A Description

I will follow the intuition expressed by Fox (1981) that Possessor Raising structures appear in instances in which a whole and a part hold different surface GRs with respect to the same verb. Fox claims that, at least in some instances, the presence of part-whole dependencies decreases the argument valence of the verb, thus turning transitives into intransitives, or ditransitives into simple transitives, as I discussed in Chapter 5.

This means that in the examples in (6), the apparently transitive (6)b is truly unaccusative, and the apparently ditransitive (6)c is really transitive.

- (6) a. Juan se levantó.
'Juan rose.'
- b. Juan levantó la mano.
'Juan raised his hand.'
- c. Juan le levantó la mano a María.
'Juan lifted Maria's hand.'

I want to propose that (6)a and (6)b are instances of raising to subject, and (6)c is an example of Possessor Raising to dative. Both of these raisings are allowed in Spanish.

In this chapter I will focus on the cases of possessor raising to positions in the domain of vP and VP, and leave the instances of raising to subject for future research.

1.2. The Possessor Raising Condition

I want to propose the following universal condition on Possessor Raising:

- (7) Possessor Raising Condition (PRC)
Languages that allow Possessor Raising have a way to assign structural Case to the raised possessor.

The different ways in which languages achieve this goal are by i) assigning the same Case multiple times (double accusative languages); ii) finding an alternative way to make their direct object visible and thus make accusative available for the raised possessor (object incorporation languages); or iii) having a second structural Case besides the one assigned to the direct object (dative possessor languages).

Of course this proposal predicts that languages without Possessor Raising will not have an alternative way to assign structural Case to the possessor. The prediction will be shown to be correct in the next section.

Notice that basically the PRC proposes treating Possessor Raising as an instance of Exceptional Case

Marking (ECM). However, given that not all languages show Possessor Raising, then it must be the case that not all languages have a structural Case that can be used for Possessor Raising when there is a direct object in the sentence already. The next sections will provide more evidence that the distinction between these two types of languages plays a role in other constructions as well.

1.3 Independent Evidence I: Ditransitive Verbs

The PRC forces us to assume that matrix verbs in Possessor Raising sentences are checking all the relevant Cases. First, we have to provide independent evidence that verbs in languages that adhere to the PRC can in fact check the relevant number of Cases in their extended projections.

There is an instance in which a verb (or the functional heads of its extended projection) needs to assign at least as many Cases as needed in Possessor Raising sentences: ditransitive verbs. When a sentence contains a subject, a direct object and an indirect object, the sentence needs to have three Cases to assign to these nominals. I assume uncontroversially that the subject gets its nominative/ergative Case checked by T, and that this Case is thus checked or not independent of the properties of the verb.

There are two more Cases to be checked then, and no other predicate around that could check any of them. I will thus assume that the verb's functional heads are checking these Cases in one of the three forms described above in section 1.2.

Therefore, when providing evidence that a language can check the Case of a raised possessor, it will be necessary to prove independently that verbs in this language can check at least two Cases. It will also be necessary to show that those two Cases take on the same

form in ditransitive sentences and in instances of Possessor Raising.

1.4 Independent Evidence II: Causatives of Transitive Verbs

The analysis defended here also requires evidence that the verbs in the languages that observe the PRC not only check two Cases, but also that the Case checked by the raised possessor is structural. Structural Case does not depend on the presence of a theta-relation, unlike Inherent Case, which can only be checked/assigned by the same predicate that assigns the nominal its thematic role. Structural Cases are typically found in instances of raising.

We thus need a structure in which the same Case checked by raised possessors is checked in the matrix clause by a DP which is thematically related to an embedded clause. I will argue that causatives of transitive verbs can potentially be one such structure.

Causatives are a topic of inquiry that has received much attention over the years. The general intuition is that, at least in some languages, the surface form of a causative sentence is monoclausal. Most analyses also assume that the underlying structure is biclausal (Rizzi 1978, Aissen and Perlmutter 1983, Baker 1988).¹

Here I will assume an underlying multiclausal analysis. What is crucial about such an analysis is that the arguments of the embedded verb are not thematically related to the matrix verb, even though those arguments end up being related to the matrix verb by getting their Cases checked in the matrix verb's extended projection.

According to Baker (1988), the change from multiclausality to monoclausality reflects the

¹ A multipredicate monoclausal underlying form has also

incorporation of the embedded verb into the matrix one. There are two classes of languages with verb incorporation. In one type, the verb incorporation is overt (i. e., the causative verb is a PF morphological affix that attaches to the embedded verb), and in the other the incorporation is covert (i. e., the causative verb is an LF-affix, as proposed, for instance, for *there-expletives* by Chomsky 1986). A third class of languages includes those whose causative sentences are biclausal throughout the derivation; this class of languages has no verb incorporation process.

Baker (1988) proposes that the causative affix that attaches to the verb in some languages is actually an independent syntactic head (the matrix verb), and that the embedded verb has to incorporate into the matrix one via head movement. Baker thought this was the most natural way to fit a rule such as RG's Clause Union in the GB theory. Under Clause Union, all the thematic dependents of an embedded clause become Case-dependents of the matrix. Translated to GB terms, in languages in which the embedded verb incorporates into the causative affix, the surface structure becomes a single clause where all the arguments of the embedded verb must get Case from the matrix causative verb. This requires that the matrix verb assign at least one structural Case (if the embedded verb is intransitive) and sometimes two (if the embedded verb is transitive: one for its subject and one for its object).

Baker's implementation differs in the details. In his account, the embedded verb is responsible for assigning accusative Case to its object, whereas the matrix verb only assigns Case to the subject of the embedded clause. Still, in a certain sense, Baker's analysis captures the spirit of the Clause Union rule, because the embedded verb

been argued for (Davies and Rosen 1988).

ends up incorporating into the matrix.

Here I want to propose a slightly different account: the Case-assigning properties of the matrix verb are independent of the incorporation. Notice that in Baker's analysis the reason why three DPs have their Case checked is because there are two verbs that do the Case-assigning. Thus, for him, the Case properties of these sentences are not different from those of a normal ECM clause: the matrix verb only assigns Case to the embedded subject, and the embedded object gets Case internally in the embedded clause. The fact that three DPs seem to get Case from the matrix verb is just an illusion under Baker's account.

Baker's account misses one fact captured by the Clause Union analysis of RG, which is that the Case configurations found in causatives is the same that we find in Possessor Raising and in ditransitive verbs. This suggests that there is no need to assume that the Case-checking is being done by the two verbs separately, but rather by the resulting combination of the two verbs.

Of course, Baker assumes a GB system where accusative is assigned under government, without movement to a functional projection above the verb, as has been assumed since Chomsky (1995:ch.2). If we assume that all the Cases are being checked in projections above the verbs, then it seems logical to ask where these projections are and whether they are related to the matrix verb, to the embedded verb, or to the combination of the two.

I want to propose that the three Cases are checked by the extended projection of the matrix verb. Under the PRC, verbs in certain languages can assign a second structural Case internal to the VP. With very few exceptions,² the

² The only one I have been able to find is the Chamorro cases discussed in Gibson and Raposo (1986). The causee gets accusative and the embedded object appears in oblique case:

embedded object takes on the Case that typically is assigned to direct objects and possessives, whereas the embedded subject checks the Case that normally goes with indirect objects and raised possessors. I will claim that there is a structural reason for this, and that general principles about the nature of movement will account for both causatives and Possessor Raising sentences in a unified way.

2. Typology of Languages

In this section, I will present a Typology of languages according to whether they observe the PRC or not, and the ways in which they implement it. Type 1 languages do not observe the PRC. Type 2 languages comply with it by incorporating one object and marking the other Accusative. Type 3 languages assign two structural Cases of the same form. Type 4 languages, finally, assign two different structural Cases to their surface objects: one is marked Accusative and the other is marked Dative. The typology is synthesized in Table 1.

Table 1

Typology of languages according to the PRC

	PR		Causative	
	Case of object	Case of Possessor	Case of object	Case of subject
type 1	*No PR		*Biclausal Causatives	
type 2	Noun Incorporation	Accusative	Noun Incorporation	Accusative
type 3	Accusative	Accusative	Accusative	Accusative
type 4	Accusative	Dative	Accusative	Dative

(i) Ha na'-taitai hãm i ma'estru ni esti na lebblu.
 3Scl CAUS-read 1Pcl the teacher OBL this LK book
 'The teacher made us read the book.'

I will present specific examples of each type in the next four subsections of the chapter.

2.1 Type 1: Languages Without Possessor Raising

In this section I want to propose an analysis of a set of English data based on the absence of Possessor Raising. The relevant contrast is shown in (8).

- (8) a. I built Mary a house.
b. *I destroyed Mary a house.

Some linguists have tried to explain the difference in terms of a constraint on Benefactive Shift with verbs like *destroy*. Mori (1997) attempted an analysis in which Benefactive Shift needs an incremental object in order to happen. The object in (8)a is incremental because the house comes to be as the event described by the verb progresses. On the other hand, the object in (8)b is not incremental, because the house disappears as the event unfolds.

However, this cannot account for other examples in which the object is not obviously destroyed:³

- (9) *I repaired Mary a car.

Notice that Possessor Raising to a double object construction is ungrammatical in English in general:

- (10) a. *I broke Mary an arm.
b. *I examined the child a kidney.

I will assume that (8)a is an instance of Benefactive Shift, whereas the sentences (8)b, (9) and (10) are ungrammatical because of the lack of Possessor Raising in English.

A question that comes to mind is why two sentences

³ Even though (9) is ungrammatical, some speakers feel that it is not as bad as (8)b. If this is true, Mori's account may be in the right track, although the

overt or covert, and that there is no single verb responsible for assigning all the Cases.

The proposal in this chapter also entails that English verbs cannot assign a second structural Case inside the VP. Thus, there is no Case in the matrix clause for the embedded object to raise to. We just saw that English does not have Possessor Raising. I take these facts to be evidence that Type 1 languages do not observe the PRC.

2.2 Type 2: Languages With Object Incorporation

As I discussed in Chapter 1, early Relational Grammar analyses (Perlmutter and Postal 1983:53) proposed the Relational Succession Law regarding raising operations:

(13) Relational Succession Law

An NP promoted by an ascension rule assumes the grammatical relation borne by the host out of which it ascends.

The direct consequence of this law is that raising can only happen to subject from subjects, to direct object from direct objects, etc. For independent reasons (ECP, multiple Spell-Out), Possessor Raising is permissible out of direct objects only.⁴ Therefore, the postulation of this law predicts that Possessor Raising can only raise the possessor to direct object.⁵

⁴ There are a few languages that allow possessor raising from subjects to nominative only, including Cebuano (Bell 1983) and Malagasy (Keenan 1972). However, Cebuano shows the relatively unusual property of allowing raising only out of subjects in general, and the examples from Malagasy reported in Perlmutter and Postal (1983) crucially involve the subject of a passive sentence. I will not try to account for these languages here, assuming that independent language-internal motivations give their subjects a special status.

⁵ As we will see later, the fact that more and more instances of Type 3 languages were found made the Law untenable as a Universal, even though it may underlie some other phenomena.

The languages in which the raised possessor checks accusative must have an alternative way to license the Case of the possessed object.

In Type 2 languages, the direct object incorporates into the verb, allowing another DP to check accusative Case. This is what we find in Southern Tiwa (Allen et al. 1990):

- (14) Ben-Ø-khwian-mu-ban.
2sS.1sO-A-dog-see-PAST
'You saw my dog.'

Southern Tiwa is a language that shows both subject and object agreement. In (14) we can see the first person singular object agreement marker on the verb. The object *khwian* 'dog' is incorporated into the verb, and thus does not check accusative Case. The verb is then free to assign accusative to the possessor, realized in this sentence as *pro*.⁶

When a verb has both a direct and an indirect object, the latter may appear as an oblique, or in a double object construction, where it shows object agreement with the verb. The two options are shown in (15) (from Allen and Frantz 1983).

- (15) a. A-khwien-wia-ban na-'ay
 2sS.3sO-dog-give-PAST me-to
 'You gave the dog to me.'
- b. Ben-khwien-wia-ban
 2sS.1sO-dog-give-PAST
 'You gave me the dog.'

As we can see, the incorporation of the object in Southern Tiwa allows the indirect object to trigger agreement with the verb, as in (15)b, much in the same way that we saw with raised possessors in (14).

⁶ In some of the languages where the possessor appears marked as accusative, it has been argued that the Possessor gets Accusative after a Dative Shift process. I discuss these languages in section 2.4

Now, given the PRC, we expect to find the same Case patterns in causatives, and the prediction is borne out. Baker (1988) gives an example of a causative in Southern Tiwa which shows exactly the same structure as a Possessor Raising construction:

(16) I-'u'u-kur-'am-bam.
 1sS.2sO-baby-hold-CAUS-PAST
 'I made you hold the baby.'

In (16), the embedded object incorporates into the embedded verb *kur* 'hold', which also incorporates into the matrix causative verb 'am. This means that accusative Case is available for the causee to check, which results in object agreement with the verb, in the same way we saw with possessor raising and with ditransitive verbs.

The conclusion then is that languages do not necessarily need two distinct structural Cases in the extended projection of the verb, as long as they have two different ways to license arguments, which is in accordance with the PRC. Southern Tiwa can do with just one structural Case, accusative, because the direct object incorporates into the verb. This makes accusative available for a raised element that needs to have its Case checked, which is what the PRC requires.

2.3 Type 3: Languages with Double Accusative

The languages in which the raised possessor is assigned accusative must have an alternative way to Case-mark the possessed object. In Chichewa Possessor Raising is available. The raised possessor in (17) has no Case-marking that differentiates it from the direct object (all Chichewa data are taken from Trithart 1977 through Baker 1988):

(17) Fisi ana-dy-a kalulu nsomba.
 hyena PAST-eat-ASP hare fish
 'The hyena ate the hare's fish.'

However, the fact that the possessor appears in front

of the possessed object makes the sentence parallel to a corresponding example with a ditransitive verb, such as (18):

- (18) Joni ana-pats-a amai ake nthochi.
J PAST-give-ASP mother his bananas
'John gave his mother bananas.'

The example shows that, even though no overt marking appears on the DPs, the order is IO-DO. I will assume that this order reflects a structural distinction between the two instances of accusative Case checked by the matrix verb.

Because in (18) both accusative DPs are arguments of the verb, it does not suffice as evidence that the PRC is being observed. However, when we look at a causative of a transitive verb, such as (19), we find that the causee appears in the same position where we found the raised possessor in (17), and the indirect object in (18).⁷

- (19) Catherine ana-kolol-ets-a mwana wake chimanga.
C PAST-harvest-CAUS-ASP child her corn
'Catherine made her child harvest the corn.'

I take (19) to be evidence that both instances of accusative in Chichewa are structural Cases, since neither of the two accusative DPs is an argument of the matrix verb.

The conclusion is that Chichewa can check two structural Cases in its extended projection. One is the instance of accusative that we find with normal direct objects. The second Case, also accusative, is the one that

⁷ It is not completely clear what the nature of these cases is. Baker (1988) argues for a double accusative analysis of Bantu languages in general, including Kinyarwanda and certain dialects of Chichewa. He claims that both objects can passivize and behave in symmetric ways across different constructions. However, Kimenyi (1980) gives arguments that in fact some Kinyarwanda constructions distinguish between direct and indirect objects, suggesting that there may be a dative/accusative distinction. The issue is not completely settled.

we find for causees of transitive verbs and raised possessors.

As we can see, what is common to the Type 2 and Type 3 languages, where the raised possessor is marked accusative, is that there exists an independent process in the language that checks the Case of the direct object. In languages of Type 2, this process is the incorporation of the object into the verb. In languages of Type 3, the verb appears capable of assigning accusative to two different DPs.

Other languages that belong in this type are Korean (Maling and Kim 1982),⁸ Japanese, or Kinyarwanda (Kimenyi 1980).

2.4 Type 4: Languages With Possessor Raising to Dative

A fourth type of language allows checking of dative Case by a raised possessor.⁹ Type 4 seems to be the most extended. It includes several Romance languages (Masullo 1992; for other views on the same data see Kayne 1975, Kempchinsky 1992, Mirto and Rosen 1993), Albanian (Hubbard 1985), Georgian (Harris 1981), Choctaw (Davies 1986), Sierra Popoluca (Marlett 1986), Basque, Hebrew (Landau 1999), and Tzotzil (Aissen 1987), among others.

Before I enter the specifics of the data, there are some issues that need to be discussed. First, some of these languages have an independent process called Benefactive Shift, which allows a benefactive argument to check dative Case. This means that languages of Type 4 tend to exhibit massive ambiguity between possessor

⁸ Korean shows a pattern of double accusative for Possessor Raising (Maling and Kim 1992, Ura 1996, Cho 1998). Its causatives, however, alternate between dative, accusative and nominative marking for the causee (Gerdtz 1990).

⁹ As more and more languages of this type were found, the Relational Succession Law could not be considered a

raising and benefactive shift. We saw an example from Albanian in (11). Choctaw (Davies 1986) shows the same ambiguity:

- (20) Issoba chim-obinili-li-tok
horse 2DAT-ride-1NOM-PAST
'I rode your horse.'
'I rode the horse for you.'

In Choctaw, datives trigger agreement on the verb. The second person agreement in (20) can correspond either to a raised possessor or to a shifted benefactive. Something similar occurs in Spanish, in the presence of a doubled dative clitic:

- (21) Le he tirado la casa a María.
cl-D have-I thrown the house to M.
'I have destroyed Mary's house.'
'I have destroyed the house for Mary.'

This ambiguity has led some linguists to propose that these constructions do not really involve Possessor Raising, but always involve Benefactive Shift. However, the difference in meaning suggests that these are two different derivations with a common spell-out.

Second, in some of the languages where the possessor appears marked as accusative, it has been argued that the Possessor checks Accusative after a Dative Shift process. Such a language is Tzotzil (Aissen 1987)¹⁰, where Dative Shift is obligatory. The evidence for such a Shift comes from the presence of the applicative affix *be* on the verb:

- (22) L-i-s-k'el-be-ik j-ch'amaltak li Xune
ASP-1sO-3sS-watch-IO-Pl 1s-children the John
'John watched my children.'

Notice that in Tzotzil the object agreement may be split. In fact, when Dative shift has occurred, the shifted object triggers person agreement on the verb, but

universal anymore.

¹⁰ Sierra Popoluca (Marlett 1986) shows a similar pattern, as well as some instances of alienable possessor raising in Kinyarwanda (Kimenyi 1980).

the original direct object may leave a plural marker on the verb as well, as we see in (22).

The structure in (22) is parallel to that of a simple ditransitive sentence in Tzotzil:

- (23) L-i-y-ak'-be tak'in li Xune
ASP-1sO-3sS-give-IO money the Xun
'Xun gave me the money.'

The analysis of a sentence like (22) must involve the same process that allows indirect objects to check accusative in (23). Thus, it is not clear whether Tzotzil is a true instance of raising to accusative. For the time being, I will assume Aissen's analysis, by which the process of accusative Case assignment is independent from the raising operation, and group Tzotzil with the languages where the raised possessor is assigned a form of dative.¹¹

Finally, it must be pointed out that the same situation is found in causatives in Tzotzil, where both the object of the embedded verb and the causee appear as accusative, but only the causee triggers person agreement on the verb (Aissen 1987):

- (24) 7a li Xune, l-i-y-ak'-be j-tuch' turasnu
Top the X. ASP-1sO-3sS-let-IO 1sS-cut peaches
'Xun let me cut peaches.'

Once again, in (24), the causee triggers object agreement on the verb. I take this to be an indication that the causee is marked with accusative Case. I will not make a choice here as to whether languages like Tzotzil are Type 3 or Type 4. I will concentrate on languages with dative marked possessors, leaving the analysis of more problematic languages for future research.

Basque is a very good example of a Type 4 language.

¹¹ See Ormazabal and Romero (1999) for a minimalist analysis of dative shift which involves the incorporation of an applicative preposition into the verb, which could be applied to Tzotzil, Kinyarwanda and Sierra Popoluca.

Basque, as is well-known, is an ergative language that shows three-way agreement on the auxiliary. The indirect object of the ditransitive verb in (25) is marked dative, and also triggers dative agreement on the verb:

- (25) Joni liburua eman diot.
 Jon-Dat book-the give have-1sE-3sA-3sD
 'I gave the book to Jon.'

By the PRC, we expect Basque to allow raised possessors to check dative. This means that a raised possessor should both show dative marking, and trigger dative agreement on the verb. The prediction is borne out:¹²

- (26) Joni eskua ikusi diot.
 Jon-Dat hand-the see have-1sE-3sA-3sD
 'I saw Jon's hand.'

The raised possessor *Joni* in (26) checks dative Case, as shown by the marking on the noun and the agreement on the verb.

But, once again, the evidence that dative in Basque is a structural case must come from causatives of transitive verbs. We expect the causee in that type of sentence to check dative in the matrix clause. That is indeed the case (Castillo 1995):¹³

- (27) Joni liburua eroski arazi diot.
 Jon-Dat book-the buy make have-1sE-3sA-3sD
 'I made Jon buy the book.'

In light of (27), we must conclude that both absolutive and dative must be structural in Basque, given that neither of the two DPs marked by these Cases is an argument of the matrix verb *arazi* 'make', but they show

¹² Thanks to Itziar San Martín for the additional Basque data.

¹³ Spanish and the other Romance languages, to the extent that they allow possessor raising, show a very similar pattern, with the causee of the transitive verb and the raised possessor marked dative. In Chapter 5, I provided an analysis that makes Spanish be a Type 4 language (see

agreement on the matrix auxiliary verb associated with it.

It is worth noting that the incorporation of the causative and embedded verbs does not occur overtly in Basque. Baker (1988) proposes that in some languages the causative verb is an LF-affix, which forces the embedded verb to incorporate covertly. Even though on the surface the two verbs appear separated in the sentence, the pattern of Case checking in an LF-incorporation language is the same as in languages with overt incorporation: the embedded object checks accusative, and the causee gets the leftover structural Case of the matrix verb, dative in this instance.

2.5 Conclusion

In this section I have shown that there is a typology that divides languages into four types, according to their observance of the PRC. Type 1 languages do not observe the PRC, because the verb in these languages only has a structural Case to check, and, since the direct object checks it in would-be possessor raising situations, the possessor does not have a Case to check in the matrix clause.

Types 2, 3 and 4 all share their observance of the PRC, even though it is implemented differently in each type. What is important is that the Cases checked by the raised possessors are independently shown to i) be checked by the matrix verb, by showing a parallel with indirect objects; and ii) be structural, by appearing on causees of transitive verbs in causative sentences.

3. The Locus of Case Checking and Parametric Variation

The combination of the observance or not of the PRC and the different ways in which languages implement the

Maier 1995 for an analysis of causatives in Spanish).

condition has given us a typology of four kinds of languages. In this section I want to propose an analysis that will explain the differences among languages in this issue.

There seem to be several parameters involved in possessor raising. On the one hand, languages may incorporate objects into the verb or not. If languages do not incorporate objects, then two Cases must be made available for direct and indirect objects. A second parameter will decide whether the two Cases are structural, or both inherent, or one is inherent and the other structural. Finally, a third parameter will involve the form of the second structural Case, whether an instance of multiple accusative or dative.

The combination of these three parameters gives us a number of possible languages, which I have schematized in (28).¹⁴

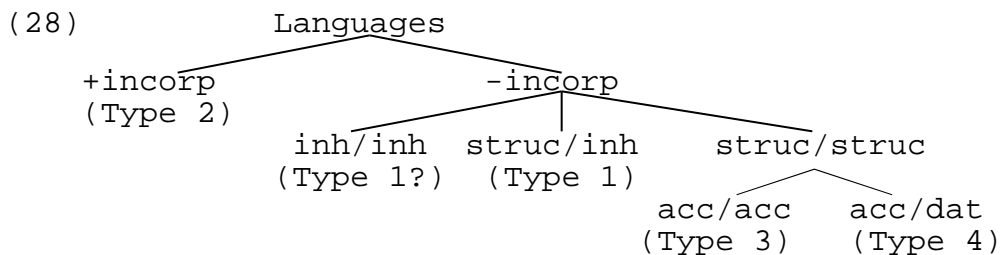

Following Chomsky (1995:ch. 4), I will take the functional projection of v^0 to be the primary locus of accusative Case. I will also follow the proposal in Sportiche (1995) that there are two different 'voices', or flavors to v , represented by the heads $vDat$ and $vAcc$, whose descriptive names imply that they check dative and

¹⁴ Languages with only inherent Cases in the extended projection of V (excluding T) may include Cebuano (Bell 1983) or Malagasy (Keenan 1972, Perlmutter and Postal 1983). In these languages, raised possessors appear with nominative Case only. I consider them to be Type 1, because they do not observe the PRC, in the strict sense of raising the possessor to a v -projection.

accusative respectively. Languages can realize these heads in different ways, especially regarding their Casual properties, the number of Cases available in each head, and the nature (inherent or structural) of its Case. These characteristics allow us to analyze the typology presented in section 2.

3.1 Type 1 Languages

I have said that Type 1 languages are characterized by lack of possessor raising, and by pervasively biclausal causatives, and I have proposed that this reflects a failure to observe the PRC.

According to the parametric options shown above, languages of Type 1 lack a structural Case that can be assigned to a nominal other than the primary one bearing accusative. English, for instance, has a structural accusative Case, as shown by instances of ECM, but, once this Case has been checked, there is no other structural Case available.¹⁵

There is evidence of two types for this claim. First, when accusative is checked by a raised subject, as in a causative sentence, such as (12), repeated here as (29). (29) I made John buy the book.

¹⁵ This correlates with the lack of verb incorporation (overt or covert) in causatives, given that, if the two verbs combined into one, there would not be enough Cases for all the arguments of the embedded verb. However, I fall short of proclaiming a dependence between verb incorporation and the PRC, given that the embedded verb could still check some Cases in the embedded clause before incorporation happens.

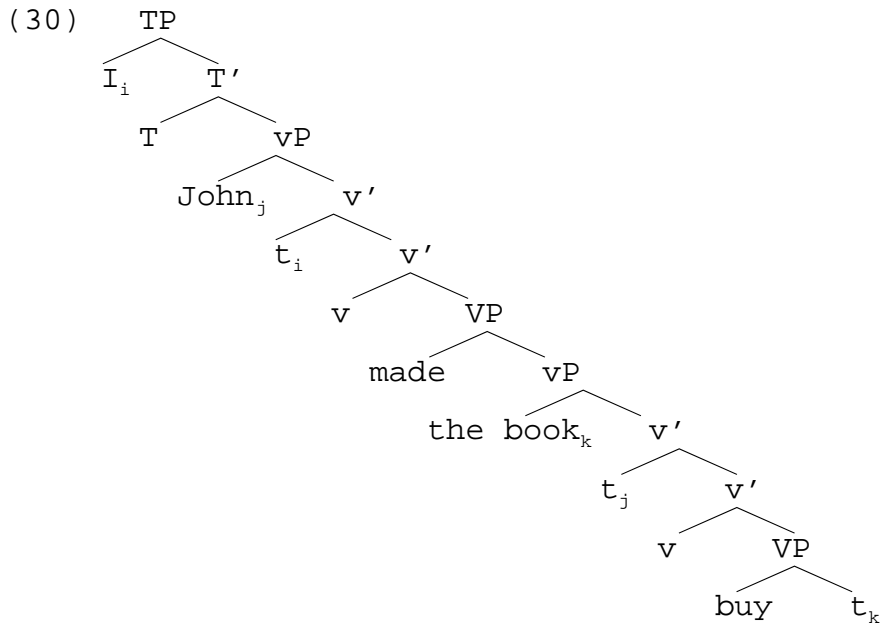

The structure in (30) does not differ from any other type of ECM sentence in English, where the embedded subject, in this sentence *John*, checks the matrix accusative Case. Obviously this is an instance of structural accusative, and no other form of structural Case is available. Thus, the embedded object must check its Case in the v-projection of the embedded verb, yielding a biclausal causative.

Second, even if the form of accusative being checked could be thought of as being inherent, as with possessed direct objects, the checking of this Case precludes the checking of a second, structural instance of accusative, thus preventing a possessor from being raised to the matrix v-projections.

I will then assume that Type 1 languages can only have dative shift with dependents of the matrix verb, which are susceptible of checking/being assigned an inherent Case.

3.2 Type 2 Languages

Recall that in Type 2 languages a structural Case is freed by means of incorporating the direct object into the

verb, as we saw for Southern Tiwa.

Chomsky (1995:ch. 4) allows the parameterization of the number of specifiers that can be hosted by a head. However, Type 2 languages can achieve the same result as languages which allow multiple specifiers, because they find two alternative sources to have the Case of a nominal checked. In order for a Type 2 language to do so, we have to assume that Case can also be checked by incorporation into a head. This is not surprising, since a position of adjunction to the head of a phrase is also defined as pertaining to the checking domain of that head (Chomsky 1995: ch. 3).

Let us see how to derive a possessor raising sentence in Southern Tiwa, such as (14), repeated here as (31).

(31) Ben-Ø-khwian-mu-ban.
2sS.1sO-A-dog-see-PAST
'You saw my dog.'

In (31), the possessed term incorporates into the verb, thus freeing accusative Case for the possessor to check, as in the structure in (32).¹⁶

¹⁶ I understand that there are issues in (32) having to do with the Head Movement Constraint, which I do not have space to discuss here. Among them, whether the noun incorporates into V first, or directly into v, and whether it also stops in the DP-internal D and Agr heads. I leave the issue for future research, assuming the specifics of the analysis are not crucial to the point made here.

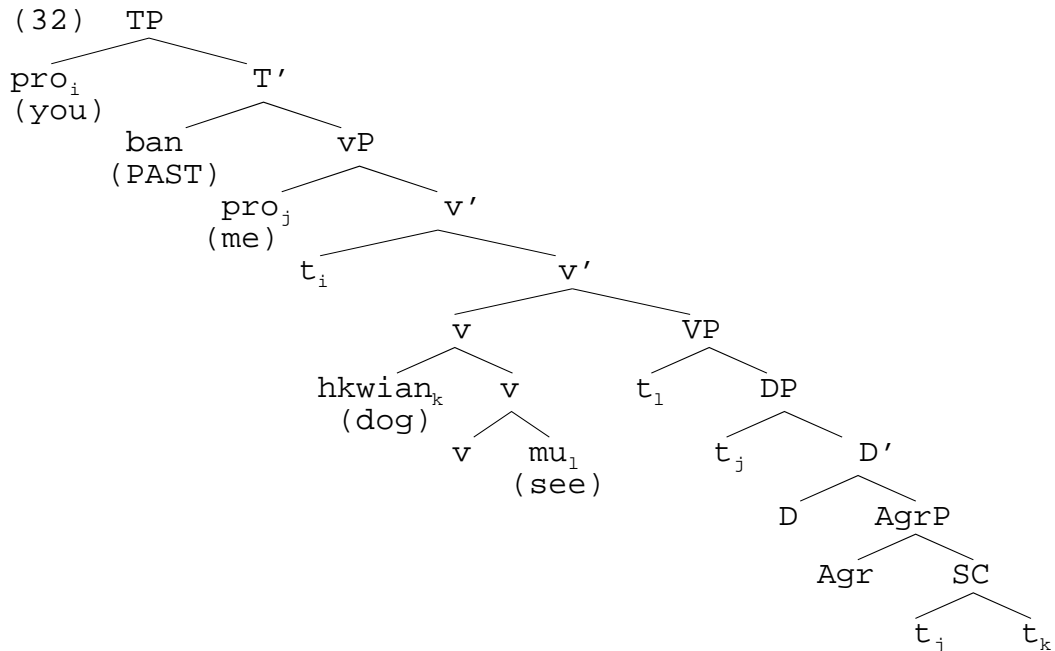

The structure in (32) is a typical possessor raising structure, in which the possessor uses [Spec,DP] as an escape hatch to get out of the big DP. The possessed, on the other hand, moves via head movement to incorporate into v, where its Case is checked. It has to be assumed that this incorporation is enough to check the Case of the big DP, assuming perhaps that the movement of the possessed brings D^0 along with it. It must also be assumed that this incorporation does not check the accusative Case of the verb, because the configuration is not the right one.

At the same time, this frees up one specifier position for the possessor to check accusative Case in a Spec-head relation.

A similar situation is found in causatives, such as (16), repeated here as (33).

(33) I-'u'u-kur-'am-bam.
 1sS.2sO-baby-hold-CAUS-PAST
 'I made you hold the baby.'

In this instance, the embedded object is incorporated into the verb, and that allows the causee to check

accusative:

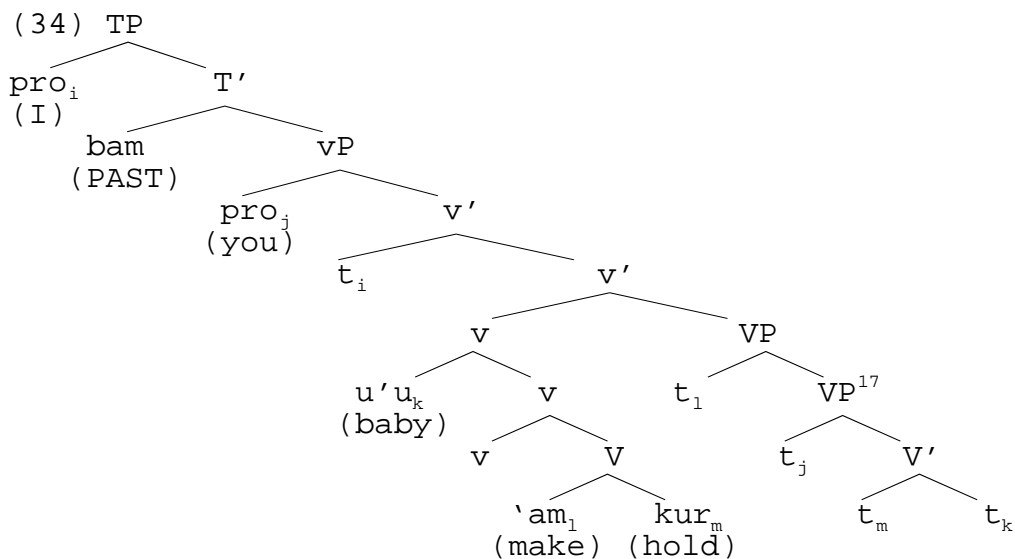

As we can see, Type 2 languages have a way to observe the PRC which involves the incorporation of the argument that normally would check accusative Case. This makes the Case available for other DPs to check, and, given that the Case is structural, as shown by the structures in (32) and (34), raised elements can check it.

3.3 Type 3 Languages

Type 3 languages have the characteristic of allowing multiple accusative checkings. In these languages, both instances of accusative are structural, which allows this Type to comply with the PRC.

I will assume that the number of specifiers that can be hosted by a head can be parameterized (Chomsky 1995:ch. 4). I will thus assume that in languages such as Chichewa or Korean v^0 allows several DPs to check its accusative Case.¹⁸

¹⁷ Alternatively, the embedded clause may have a v-projection which, by virtue of incorporation, does not have to discharge its accusative Case. This v-projection would assign the external theta-role, but that is not crucial here.

¹⁸ Baker (1988) also distinguishes between 'true double

A relevant example of possessor raising in a Type 3 language is the Chichewa (17), repeated here as (35).

(35) Fisi ana-dy-a kalulu nsomba.
 hyena PAST-eat-ASP hare fish
 'The hyena ate the hare's fish.'

In (35), the possessed term checks accusative into what I will consider to be the inner [Spec,vP], whereas the possessor checks a second instance of accusative in the outer specifier, as in the structure in (36).

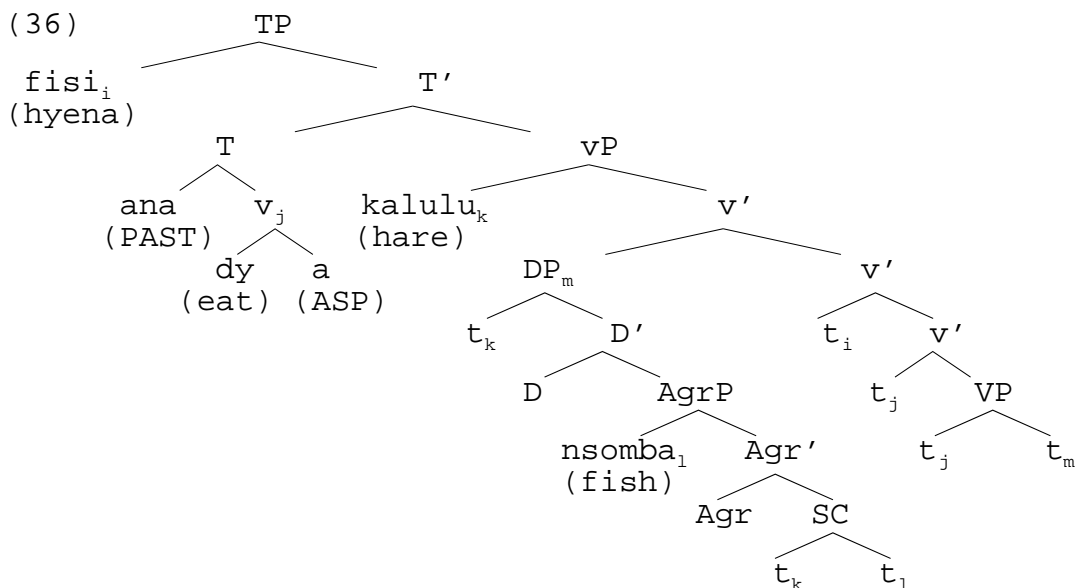

Assuming that both instances of accusative in (36) are structural allows us to derive not only the possessor arising, but also the parallel causative in (19), repeated here as (37).

(37) Catherine ana-kolol-ets-a mwana wake chimanga.
 C PAST-harvest-CAUS-ASP child her corn
 'Catherine made her child harvest the corn.'

Again, in this instance, we have a double object structure, where the causee gets the outer specifier of

object languages', and 'non-true double object languages', according to whether the two objects behave completely parallel to each other in terms of syntactic behavior. I will not make a distinction here between these two types, assuming that there could be a variation as to whether two specs of the same head are always treated the same or not.

vP, and the embedded object gets the inner spec:

(38)

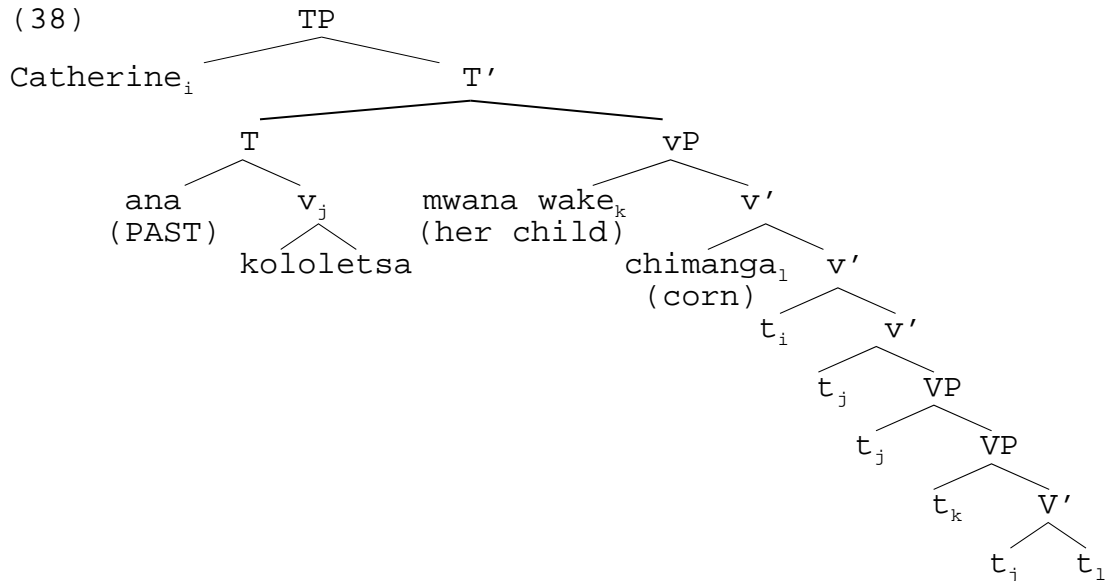

Let me notice as a final note that the number of multiple accusatives in Type 3 languages may actually be greater than two. Assuming in principle that the parameterization may be as such, it has been proposed that languages like Korean allow multiple possessors to be raised and marked accusative by the same v^0 (Cho 1998).¹⁹

(39) Mary-ka John-ul pal-ul kkup-ul cha-ess-ta.
M-NOM J-ACC foot-ACC end-ACC kick-PAST-DECL
'Mary kicked the end of John's foot.'

Most languages restrict the number of raised possessors to one, presumably for independent reasons having to do with Extraction Domains. However, as we see, nothing precludes in principle a multiplicity of checkings of accusative in languages of Type 3.

I have shown that the way in which Type 3 languages

¹⁹ Kimenyi (1980) reports that Kinyarwanda allows multiple raised possessors only if the possessors are of different types. It is thus possible to find a raised alienable possessor next to another raised inalienable possessor. However, the former is the result of an applicative incorporation, whereas the latter is an instance of straight Possessor Raising. I will assume that the fact that the two processes are potentially different makes the

comply with the PRC is by allowing multiple specifiers of vP to check multiple instances of accusative Case. As expected, the patterns found in possessor raising and causatives of transitive verbs suggest that in these languages both instances of accusative are structural, and thus allow them to observe the PRC.

3.4 Type 4 Languages

Finally, I have proposed that languages of Type 4 observe the PRC by checking two different structural Cases, dative and accusative, in the v-projection of the matrix clause.

I will follow Sportiche in assuming that dative and accusative are checked by two different v-heads, aptly named vDat and vAcc. I will disagree with him, however, in the structural positioning of these heads. I will assume that vDatP dominates vAccP, as has been assumed by other authors (see Uriagereka 1999).

I will also assume that vDat is not contingent on the presence of an external argument, the way Chomsky (1995) assumes vAcc to be (although see my comments on the issue in chapter 5, section 4.3.2). Even though we must look for more robust evidence one way or the other, as a preliminary argument, I will show that some Basque unaccusative verbs can assign dative Case. Such a verb is *agertu* 'appear' (Addis 1993):²⁰

(40) Bapatean mamu bat agertu zaio Eduri.
suddenly ghost one appeared have-3sA.3sD Edu-DAT
'Suddenly, a ghost appeared to Edu.'

Thus, I will take this Basque class of verbs (known among Basque linguists as *nor-nori*, literally 'whom-to

Kinyarwanda case different from the one found in Korean.
²⁰ A similar structure could be involved in the so-called psych verbs in Romance languages, following the analysis by Belletti and Rizzi (1988), which takes them to be unaccusatives that assign dative as well.

whom', meaning that these verbs assign absolutive and dative, but not ergative Case) to show that the correlation between v^0 and the presence of structural dative does not hold.

Possessor Raising in Type 4 languages is straight forward then. The possessor raises to vDat, where it checks dative, whereas the possessed element checks accusative in vAcc, much in the way we saw for Spanish in chapter 5.

- (41) Juan le vio las piernas a María.
 J cl-D saw the legs to M
 'Juan saw Mary's legs.'

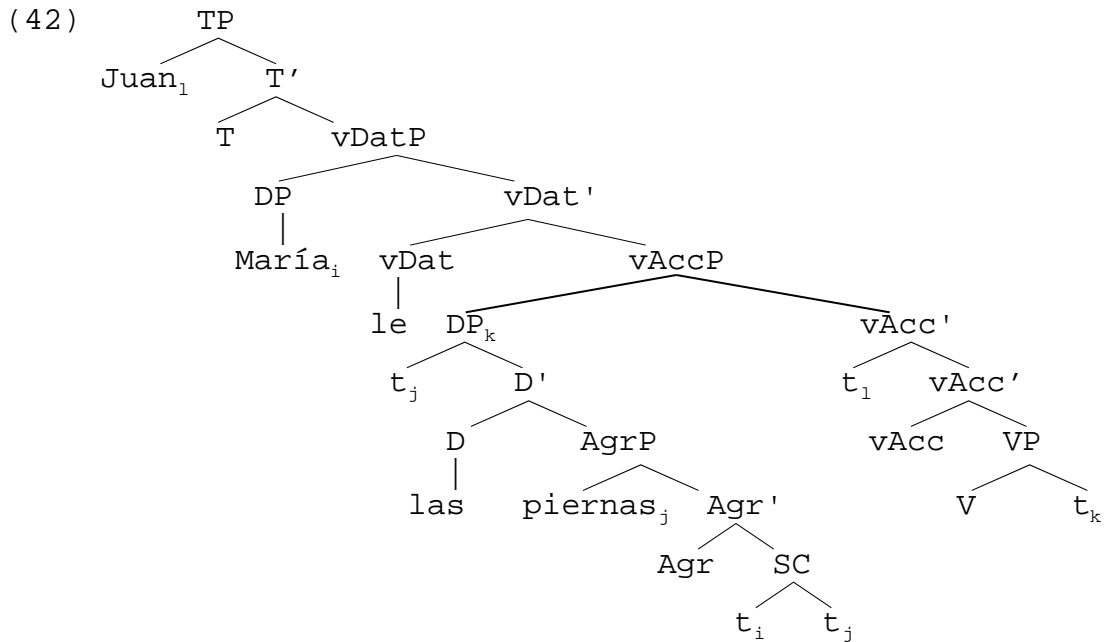

As we saw in chapter 5, in Spanish vDat is realized as a doubling clitic, but a similar structure in Basque would show agreement on the auxiliary verb, instead of a clitic pronoun.

Once again, causatives of transitive verbs will be the proof that dative is a structural Case in Type 4 languages.²¹ A parallel Spanish example is given in (43).

²¹ Masullo (1992) agrees that dative is structural in Spanish, even though his analysis involves the

- (43) Juan le hizo comprar el libro a María.
 J cl-D made buy the book to M
 'Juan made María buy the book.'

The reason why I believe that vDat must be higher than vAcc is because of the Minimal Link Condition (MLC). It is a well-known fact that, whereas there are many Type 4 languages where causees check Dative, and embedded objects check Accusative, there is no evidence of languages that pattern the opposite way.

Since the starting position of the causee is higher than that of the embedded object, in order to have both arguments move to their respective Case positions without violating the MLC, the Case position of the causee must also be higher than that of the embedded object. I thus assume that, as a general rule, vDat is higher in the tree than vAcc.

The derivation of the Spanish causative example (43) then will be as in (44) (abstracting away from verb movements).

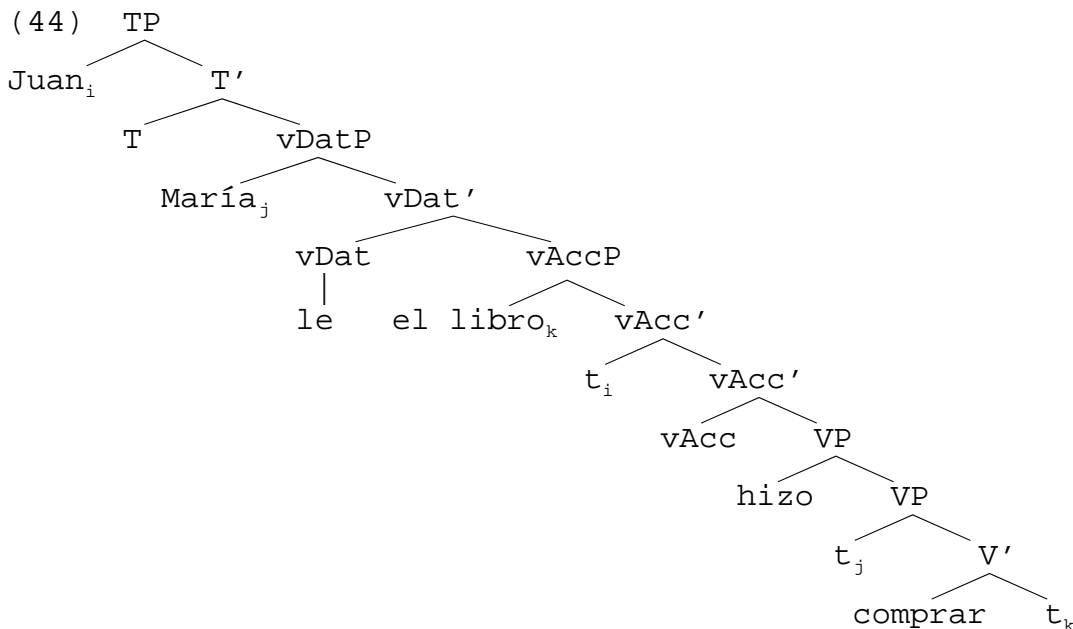

incorporation of a head into the verb in all cases of dative marking in Spanish.

In accordance with the MLC, the movement of the two embedded arguments draws a pattern of crossing paths. The causer, or matrix subject, is generated in the inner specifier of vAccP, but it has no problem reaching [Spec,TP], given that it can skip the dative causee in [Spec,vDatP], and that outer specifiers in the same projection do not count as possible targets for movement.

I have thus shown that assuming a clause structure with vDatP dominating vAccP, and the assumption that dative in Type 4 languages is a structural Case, allows us to derive the properties of this kind of language with regard to their observance of the PRC.

3.5 The 3-Chomeur Ban

Before finishing this chapter, I want to discuss an issue relevant to languages with possessor raising, which the RG literature called the 3-Chomeur Ban, proposed for Hubbard (1980) for Albanian, Harris (1976) for Georgian, Aissen (1979) for Tzotzil, and Bickford (1986) for Kinyarwanda.

According to this ban, a possessor cannot be raised and check dative if the sentence already has a goal argument. The following Kinyarwanda example from Bickford (1986) shows the ban in action:

- (45) *Umugóre á-r-érek-a umuhuûngu umukuoôbwa
 woman she-PRES-show-ASP boy girl
 amaguru
 legs
 'The woman is showing the boy the girl's legs.'

Spanish actually shows a similar ban, as discussed in Masullo (1992). (46) is ambiguous: the dative can be understood as a goal or as a raised possessor.

- (46) Le he enviado la carta a María.
 cl-D have-I sent the letter to M
 'I have sent the letter to María.'
 'I have put María's letter in the mail.'

On the other hand, if there is a goal in the

sentence, then the possessor cannot be raised.

- (47) #Le he enviado la carta a María a Juan.
 cl-D have-I sent the letter to M to J
 'I have sent Juan the letter to María.'
 'I have sent the letter (addressed) to María for Juan.'
 *'I have sent María's letter to Juan.'

There may be two reasons for this ban on Possessor Raising in presence of a goal argument. First, the reason could be structural. If goal arguments are higher than direct objects (say, in [Spec,VP]), then the ban may reduce to an MLC violation: the goal argument is closer to vDat than the possessor sitting in [Spec,DP] of a lower argument.

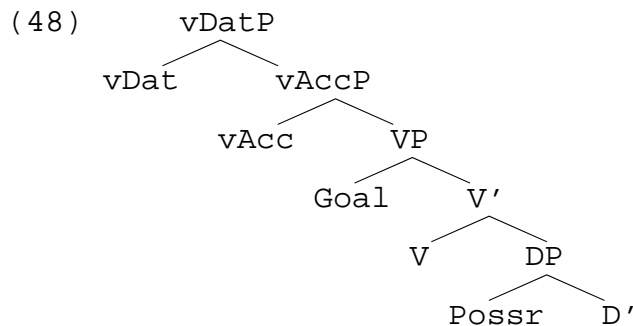

On the other hand, there could also be a general ban on the checking of a structural Case when the same Case may be assigned inherently to an argument of the head. This would mean that the checking of structural Case is a last resort mechanism, and that the assignment of inherent Case is preferred if available.²²

4. Conclusion

In this chapter I have proposed an account of Possessor Raising which crucially depends on the condition repeated below:

²² This idea is hinted at in Castillo et al. (1999) to explain the absence of object expletives in English.

(49) Possessor Raising Condition (PRC)

Languages that allow Possessor Raising have a way to assign structural Case to the raised possessor.

This condition forces languages with Possessor Raising to have two structural Cases assigned in the extended projection of V, or an alternative way to Case-mark one of the internal arguments. I have proposed a typology of languages that both observe and do not observe the PRC.

The analysis naturally extends to other instances in which two structural Cases have to be available, such as causative constructions with embedded transitive verbs. In languages in which the embedded verb incorporates into the causative, both the subject and the object of the embedded verb need to raise to the matrix clause to have their Cases checked. In order to allow such a construction, the language needs a way to check the Case of two DPs that are not dependents of the matrix verb. Thus, the languages that present this kind of causative are predicted to have Possessor Raising as well. This is the case across a large number of languages.

A number of parameters regarding the ways in which Cases for internal arguments are checked have been discussed in this chapter as well, leading up to four types of languages.

Questions to be answered in further research include the most obvious one: why does Possessor Raising happen at all when all languages have a way to license the possessor internal to its host DP. I have speculated elsewhere (Castillo 2000) that maybe the matrix clause attracts embedded arguments and verbs for learnability reasons. Whatever the reason is, I expect it to be deeper than the postulation of unmotivated features that trigger all these movements.

CHAPTER 6
FUTURE LINES OF RESEARCH

This dissertation takes an approach that has consequences for the linguistic theory which are worth exploring, and suggest lines of research for future work.

First, there is a marked differentiation between what is considered lexical-conceptual, and what is considered intentional. The official Minimalist line has been that these two elements are part of the same interface, namely LF. However, the split proposed in this dissertation suggests that these could be two separate interfaces.¹

If the view defended here is on the right track, conceptual relations are basic, primitive, and limited in number. The bulk of this dissertation makes use of a basic conceptual relation, the integral, expressed syntactically by way of a small clause. From this basic relation, we have analyzed a number of different structures and interpretations, which arise on the course of the derivation towards the other side, the LF interface. Integrals are also recursive, giving rise to an even greater number of possible derivations at LF.

On the way to LF, there arises a variety of intentional concepts. In this dissertation, I have explored some of them, such as reference, agreement, scope, and others. The course of the derivation also serves to rule out derivations, either because of ungrammaticality, or for uninterpretability reasons.

The question of what relations belong to which component, the lexico-conceptual or the intentional, is a theoretical and empirical one. Future research must make decisions one way or the other towards the definition of these two components of the grammar.

¹ A view suggested in Uriagereka (2000).

Another issue that is worth exploring is the boundary between the lexicon and the syntactic component. This topic was a taboo for many years, and it still is, as the recent arguments between atomists and decompositionists.² This dissertation obviously takes the second position. Lexical entries are assumed to be more basic and less sophisticated than the conventional wisdom usually implies. Thus, distinctions like those between predicates and entities, mass terms and count nouns, relational and non-relational nouns, and further perhaps, animate and non-animate, noun and name, to mention some of them, are taken out of the lexicon. These are assumed to be compositional concepts generated in the syntactic component by associating lexical and functional items in basic relations such as the integral.

Eventually, the goal of the Warps program is to be able to cross the boundaries between the major categories in syntax. The differences between determiners and prepositions have already been put in doubt, and the lexical relation between nouns and verbs has also been explored as one of containment and not necessarily opposition. The ultimate goal is to understand how categories are formed, combined and organized in the language faculty.

Another issue that this dissertation touches upon is the nature of displacement, and its technical implementations. The notion that an element moves out of a certain syntactic domain is still a puzzle for linguists. This dissertation has dealt with examples of raising possessors, and has proposed that the reason for this movement is that certain possessors can be associated with Cases that must be checked outside their syntactic domain.

² See Fodor and Lepore (1998, 1999), Pustejovsky (1998), Hale and Kayser (1999) and Pietroski and Uriagereka (2001).

Why this is remains a mystery. It is true that there are some interpretive implications for the movement that point at likely derivational targets in the intentional component. The nature of this movement is an issue that grants further research.

This dissertation has also studied some issues of typology, such as the dichotomy classifier/number, the presence or absence of possessor raising, and the forms that the latter takes in different languages. The understanding of language variation is one of the major goals of linguistic theory, and steps should be taken to further our knowledge on this topic.

REFERENCES

- Abney, S. 1987. *The Noun Phrase in Its Sentential Aspect*. MIT Ph. D. Dissertation. Cambridge.
- Addis, K. 1993. Paradigm Trimming in Basque. *Linguistics*, 31: 431-474.
- Aissen, J. 1987. *Tzotzil Clause Structure*. Dordrecht: Reidel/Kluwer.
- Aissen, J. 1990. 'Towards a Theory of Agreement Controllers.' In B. D. Joseph and P. M. Postal, eds., *Studies in Relational Grammar 3*, pp. 279-320. Chicago: University of Chicago Press.
- Aissen, J. and D. Perlmutter 1983. 'Clause Reduction in Spanish.' In D. M. Perlmutter, ed. *Studies in Relational Grammar 1*, pp. 360-403. Chicago: University of Chicago Press.
- Allen, B. and D. Frantz 1983. 'Advancements and Verb Agreement in Southern Tiwa.' In D. M. Perlmutter, ed. *Studies in Relational Grammar 1*, pp. 303-316. Chicago: University of Chicago Press.
- Allen, B. J., D. G. Frantz, D. B. Gardiner and D. M. Perlmutter 1990. 'Verb Agreement, Possessor Ascension and Multistratal Representation in Southern Tiwa.' In B. D. Joseph and P. M. Postal, eds. *Studies in Relational Grammar 3*, pp. 321-383. Chicago: University of Chicago Press.
- Aschan, T. 1995. *Finnish Existentials*. University of Maryland Ms.
- Atutxa, A. 2000. *Telicity: A Lexical Feature or a Derived Concept?* University of Maryland Ms.
- Baker, M. 1985. The Mirror Principle and Morphosyntactic Explanation. *Linguistic Inquiry* 16: 373-416.
- Baker, M. 1988. *Incorporation*. Chicago: University of Chicago Press.
- Baker, M., K. Johnson and I. Roberts 1989. Passive Arguments Raised. *Linguistic Inquiry* 20: 219-251.
- Barker, C. 1995. *Possessive Descriptions*. Stanford: CSLI.

- Bell, S. J. 1983. 'Advancements and Ascensions in Cebuano.' In D. M. Perlmutter, ed. *Studies in Relational Grammar 1*, pp. 143-218. Chicago: University of Chicago Press.
- Belletti, A. 1988. The Case of Unaccusatives, *Linguistic Inquiry* 19: 1-34.
- Belletti, A. and L. Rizzi 1988. Psych Verbs and Theta Theory. *Natural Language and Linguistic Theory* 6: 291-352.
- Benveniste, E. 1971. *Problems in General Linguistics*. Coral Gables: University of Miami Press.
- Bernstein, J. 1991. DPs in French and Walloon: Evidence for Parametric Variation in Nominal Head Movement. *Probus* 3: 101-126.
- Bernstein, J. 1993. The Syntactic Role of Word Markers in Null Nominal Constructions. *Probus* 5: 5-38.
- Bickford, J. A. 1988. 'Possessor Ascension in Kinyarwanda.' In A. Farley, P. Farley and K.-E. McCullough, eds. *CLS 22. Part 1*, pp. 129-143. Chicago: Chicago Linguistics Society.
- Bleam, T. 1999. *Leísta Spanish and the Syntax of Clitic Doubling*. University of Delaware Ph. Diss.
- Burge, T. 1975. Mass Terms, Count Nouns and Change. *Synthese* 31. Reprinted in F. J. Pelletier, ed. 1979, *Mass Terms: Some Philosophical Problems*, pp. 199-218. Dordrecht: Reidel.
- Burzio, L. 1986. *Italian Syntax: A Government and Binding Approach*. Dordrecht: Reidel.
- Castillo, J. C. 1995. 'Case Marking in Basque: Evidence from Causatives.' In R. Echeppare and V. Miglio, eds. *University of Maryland Working Papers in Linguistics 3*, pp. 1-19. College Park: Department of Linguistics.
- Castillo, J. C. 1997. *The Syntactic Import of Selection: Extraction out of DP*. University of Maryland Ms.
- Castillo, J. C. 1998a. 'A Syntactic Account of Perfective and Possessive Verb Selection in Romance Languages.' In J. Lema and E. Treviño, eds. *Theoretical Analyses on Romance Languages*, pp. 159-174. Philadelphia: Johns Benjamins.

- Castillo, J. C. 1998b. 'The Syntax of Container-Content Relations.' In E. Murgia, A. Pires and L. Quintana, eds. *University of Maryland Working Papers in Linguistics 6*, pp. 32-60. College Park: Department of Linguistics.
- Castillo, J. C. 2000. *¿Es posible tener una teoría formalista de la evolución del lenguaje?* University of Iowa Ms.
- Castillo, J. C., J. Drury and K. Grohmann 1999. 'The Status of the Merge Over Move Preference.' In S. Aoshima, J. Drury and T. Neuvonen, eds. *University of Maryland Working Papers in Linguistics 8*, pp.66-103. College Park: Department of Linguistics.
- Castillo, J. C. and J. Uriagereka 2000. 'A Note on Successive Cyclicity.' In M. Guimarães, L. Meroni, C. Rodrigues and I. San Martin, eds. *University of Maryland Working Papers in Linguistics 9*, pp. 1-11. College Park: Department of Linguistics.
- Cattell, R. 1976. Constraints on Movement Rules. *Language* 52: 18-50.
- Chierchia, G. 1998. 'Plurality of Mass Nouns and the Notion of "Semantic Parameter".' In S. Rothstein, ed. *Events and Grammar*, pp. 53-104. Dordrecht: Kluwer.
- Cho, S. 1998. 'A New Analysis of Korean Inalienable Possession Constructions.' In P. Tamanji and K. Kusumoto, eds. *Proceedings of the Northeast Linguistics Society (NELS) 28*, University of Toronto.
- Chomsky, N. 1955. *The Logical Structure of Syntactic Theory*. Reprinted in Chicago: University of Chicago Press, 1985.
- Chomsky, N. 1970. 'Remarks on Nominalization.' In R. A. Jacobs and P. S. Rosenbaum, eds. *Readings in English Transformational Grammar*, pp. 184-221. Waltham: Ginn.
- Chomsky, N. 1977. 'On Wh-movement.' In P. Culicover, T. Wasow and A. Akmajian, eds. *Formal Syntax*, pp. 71-132. San Diego: Academic Press.
- Chomsky, N. 1986. *Knowledge of Language. Its Nature, Origin and Use*. New York: Praeger.
- Chomsky, N. 1995. *The Minimalist Program*. Cambridge: MIT Press.

- Cinque, G. 1990. *Types of A'-dependencies*. Cambridge: MIT Press.
- Collins, C. 1997. *Local Economy*. Cambridge: MIT Press.
- Corver, N. 1998. 'Predicate Movement in Pseudopartitive Constructions.' In A. Alexiadou and C. Wilder, eds. *Possessors, Predicates and Movement in the Determiner Phrase*, pp. 215-258. Amsterdam: John Benjamins.
- Croft, W. 1994. Semantic Universals in Classifier Systems. *Word* 45: 145-171.
- Cruse, D. A. 1979. On the Transitivity of the Part-Whole Relation. *Journal of Linguistics* 15:29-38.
- Davies, W. 1984. 'Antipassive: Choctaw Evidence for a Universal Characterization.' In D. Perlmutter and C. Rosen, eds. *Studies in Relational Grammar 2*, pp. 331-376. Chicago: University of Chicago Press.
- Davies, W. 1986. *Choctaw Verb Agreement and Universal Grammar*. Dordrecht: Reidel/Kluwer.
- Davies, W. and C. Rosen 1988. Unions as Multi-Predicate Clauses. *Language* 64: 52-88.
- Delfitto, D. and J. Schrotten, 1991. Bare Plurals and the Number Affix in DPs. *Probus* 3: 155-186.
- den Dikken, M. 1998. 'Predicate Inversion in DP.' In A. Alexiadou and C. Wilder, eds. *Possessors, Predicates and Movement in the Determiner Phrase*, pp. 177-214. Amsterdam: John Benjamins.
- Diesing, M. 1992. *Indefinites*. Cambridge: MIT Press.
- Doetjes, J. 1997. *Quantifiers and Selection*. Dordrecht: HIL.
- Dowty, D. 1979. *Word Meaning and Montague Grammar*. Dordrecht: Reidel.
- Epstein, S., E. Groat, R. Kawashima and H. Kitahara 1998. *A Derivational Approach to Syntactic Relations*. Oxford: Oxford University Press.
- Español-Echevarría, M. 1995. *Inalienable Possession in Copulative Contexts and DP Structure*. UCLA Ms.
- Etxepare, R. 1997. *Speech Events and the Syntax of Focus*. University of Maryland Ph. Diss.

- Fodor, J. and E. Lepore 1998. The Emptiness of the Lexicon: Reflections on James Pustejovsky's *The Generative Lexicon*. *Linguistic Inquiry* 29: 269-288.
- Fodor, J. and E. Lepore 1999. Impossible Words? *Linguistic Inquiry* 30: 445-453.
- Fox, B. 1981. Body Part Syntax: Towards a Universal Characterization. *Studies in Language* 5: 323-342.
- Freeze, R. 1992. Existentials and Other Locatives. *Language* 68: 553-595.
- Gerdts, D. 1990. 'Revaluation and Inheritance in Korean Causative Union.' In B. D. Joseph and P. M. Postal, eds., *Studies in Relational Grammar 3*, pp. 203-246. Chicago: University of Chicago Press.
- Gibson, J. and E. Raposo 1986. Clause Union, the Stratal Uniqueness Law and the Chomeur Relation. *Natural Language and Linguistic Theory* 4: 295-331.
- Greenberg, J. 1972. Numeral Classifiers and Substantival Number: Problems in the Genesis of a Linguistic Type. *Stanford Working Papers on Language Universals* 9: 1-39.
- Grimshaw, J. 1990. *Argument Structure*. Cambridge: MIT Press.
- Grimshaw, J. 1997. Projection, Heads and Optimality. *Linguistic Inquiry* 28: 373-422.
- Hale, K. and J. Keyser 1993. 'On Argument Structure and the Lexical Expression of Syntactic Relations.' In K. Hale and J. Keyser, eds. *The View from Building 20*, pp. 53-110. Cambridge: MIT Press.
- Hale, K. and J. Keyser 1999. A Response to Fodor and Lepore, "Impossible Words?". *Linguistic Inquiry* 30: 453-466.
- Harris, A. 1981. *Georgian Syntax. A Study in Relational Grammar*. Cambridge: Cambridge University Press.
- Higginbotham, J. 1988. 'Contexts, Models, and Meanings: A Note on the Data of Semantics.' In R. Kempson, ed. *Mental Representations*, pp. 29-48. Cambridge: Cambridge University Press.
- Higginbotham, J. 1998. *Lectures at the XVII Summer Courses*. San Sebastián, University of the Basque Country.

- Hornstein, N., S. Rosen and J. Uriagereka 1994. 'Integrals.' In Nunes, J., E. Thompson and S. Varlokostova, eds. *University of Maryland Working Papers in Linguistics 2*, pp. 70-90. College Park: Department of Linguistics.
- Hubbard, P. 1985. *The Syntax of the Albanian Verb Complex*. New York: Garland.
- Jaeggli, O. 1986. Passive. *Linguistic Inquiry* 17: 587-622.
- Johnson, K. 1991. Object Positions. *Natural Language and Linguistic Theory* 9:577-636.
- Kayne, R. 1975. *French Syntax*. Cambridge: MIT Press.
- Kayne, R. 1993. Toward a Modular Theory of Auxiliary Selection. *Studia Linguistica* 47: 3-31.
- Kayne, R. 1994. *The Antisymmetry of Syntax*. Cambridge: MIT Press.
- Keenan, E. 1972. 'Relative Clause Formation in Malagasy.' In P. Peranteau, J. Levi and G. Phares, eds. *The Chicago Which Hunt: Papers from the Relative Clause Festival*, pp. 169-189. Chicago: CLS.
- Keenan, E. 1987. 'A Semantic Definition of "Indefinite NP".' In E. Reuland and A. ter Meulen, eds. *The Representation of (In)definiteness*, pp. 286-318. Cambridge: MIT Press.
- Kempchinsky, P. 1992. 'The Spanish Possessive Dative Construction: Theta-Rola Assignment and Proper Government.' In P. Hirschbühler and K. Koerner, eds. *Romance Languages and Modern Linguistic Theory*, pp. 135-150. Philadelphia: John Benjamins.
- Kempchinsky, P. 1996. 'Perfective Auxiliaries, Possession and Existence in Romance.' In Karen Zagona, ed. *Grammatical Theory and Romance Languages*, pp. 135-144. Philadelphia: John Benjamins.
- Kimenyi, A. 1980. *A Relational Grammar of Kinyarwanda*. Berkeley: University of California Press.
- Kitahara, H. 1997. *Elementary Operations and Optimal Derivations*. Cambridge: MIT Press.

- Koizumi, M. 1993. 'Object Agreement and the Split-VP Hypothesis.' In J. D. Bobaljik and C. Phillips, eds. *MITWPL 18: Papers in Case and Agreement I*, pp. 99-148. Cambridge: MIT.
- Landau, I. 1999. Possessor Raising and the Structure of VP. *Lingua* 107: 1-37.
- Landman, F. 1991. *Structures for Semantics*. Dordrecht: Kluwer.
- Lasnik, H. and M. Saito 1993. On the Subject of Infinitives. *Papers from the 27th Regional Meeting of the Chicago Linguistic Society*, pp. 324-343.
- Levin, B. 1993. *English Verb Classes and Alternations*. Chicago: University of Chicago Press.
- Lightfoot, D. 1991. *How to Set Parameters. Arguments from Language Change*. Cambridge: MIT Press.
- López Díaz, E. and L. Quintana 1996. *The Minimalist Structure of Anaphoric Constituents*. Instituto Universitario Ortega y Gasset Ms.
- Maier, N. 1995. *A Minimalist Account of Romance Causatives*. University of Iowa Ph. Diss.
- Maling, J. and S.-W. Kim 1992. Case Assignment and the Inalienable Possession Construction. *Journal of East-Asian Linguistics* 1: 37-68.
- Marlett, S. 1986. Syntactic Levels and Multiattachment in Sierra Popoluca. *International Journal of American Linguistics* 52: 359-387.
- Masullo, P. 1992. *Incorporation and Case Theory in Spanish: A Cross-Linguistic Perspective*. University of Washington Ph. Diss.
- Mirto, I. and C. Rosen 1993. *Meronyms as Predicates: An Apparent 'Inalienable Possession' Construction*. Cornell University Ms.
- Mori, N. 1997. *The Syntactic Representation of Aspect*. University of Maryland Ms.
- Müller, G. 1996. A Constraint on Remnant Movement. *Natural Language and Linguistic Theory* 14: 355-407.

- Muromatsu, K. 1994. 'Integrals in Japanese.' In J. Nunes, E. Thompson and S. Varlokostova, eds. *University of Maryland Working Papers in Linguistics 2*, pp. 136-158. College Park: Department of Linguistics.
- Muromatsu, K. 1995. 'The Classifier as a Primitive: Individuation, Referability and Argumenthood.' In R. Echeperre and V. Miglio, eds. *University of Maryland Working Papers in Linguistics 3*, pp. 144-180. College Park: Department of Linguistics.
- Neira, J. 1978. 'La oposición 'continuo'/'discontinuo' en las hablas asturianas.' In *Estudios ofrecidos a Emilio Alarcos Llorach*, vol. 3, pp. 255-279. Oviedo: Universidad.
- Nunes, J. 1995. *The Copy Theory of Movement and Linearization of Chains in the Minimalist Program*. University of Maryland Ph. Diss.
- Oehrle, R. 1977. 'Comments on the Paper by Selkirk.' In P. Culicover, T. Wasow and A. Akmajian, eds. *Formal Syntax*, pp. 317-325. San Diego: Academic Press.
- Ormazabal, J. and J. Romero 1999. *On the Syntactic Nature of the me-lui and the Person-Case Constraint*. University of the Basque Country and University of Madrid Ms.
- Ormazabal, J., J. Uriagereka and M. Uribe-Etxebarria 1994. *Word Order and Wh-Movement: Towards a Parametric Account*. Paper presented at GLOW 17, Vienna.
- Parsons, T. 1990. *Events in the Semantics of English: A Study in Subatomic Semantics*. Cambridge: MIT Press.
- Pelletier, F. J. 1979. 'Non-Singular Reference: Some Preliminaries.' In F. J. Pelletier, ed. *Mass Terms: Some Philosophical Problems*, pp. 1-14. Dordrecht: Reidel.
- Perlmutter, D. and P. Postal 1983. 'The Relational Succession Law.' In D. Perlmutter, ed. *Studies in Relational Grammar 1*, pp. 30-80. Chicago: University of Chicago Press.
- Picallo, M. C. 1991. Nominals and Nominalizations in Catalan. *Probus 3*: 279-316
- Pietroski, P. and J. Uriagereka 2001. *Dimensions of Natural Language*. University of Maryland Ms.

- Pollock, J.-Y. 1989. Verb Movement, Universal Grammar and the Structure of IP. *Linguistic Inquiry* 20: 365-424.
- Pustejovsky, J. 1998. Generativity and Explanation in Semantics: A Reply to Fodor and Lepore. *Linguistic Inquiry* 29: 289-311.
- Quintana, L. 1998. 'Meaningful Motivation behind the Syntax of Reciprocals.' In E. Murgia, A. Pires and L. Quintana, eds. *University of Maryland Working Papers in Linguistics 6*, pp. 152-178. College Park: Department of Linguistics.
- Rice, S. 1988. Unlikely Lexical Entries. *Berkeley Linguistic Society* 14: 202-212.
- Richards, N. 1997. *What Moves Where in Which Language*. MIT Ph. Diss.
- Ringen, C. 1988. 'Underspecification Theory and Binary Features.' In H. van der Hulst and N. Smith, eds. *Features, Segmental Structure and Harmony Processes*, pp. 145-160. Dordrecht: Foris.
- Ritchie, W. 1971. On the Analysis of Surface Nouns. *Papers in Linguistics* 3: 1-16.
- Ritter, E. 1991. 'Two Functional Categories in Noun Phrases: Evidence from Modern Hebrew.' In S. Rothstein ed. *Syntax and Semantics 25: Perspectives on Phrase Structure: Heads and Licensing*, pp. 37-62. New York: Academic Press.
- Ritter, E. 1992. Cross-Linguistic Evidence for Number Phrase. *Canadian Journal of Linguistics* 37: 197-218.
- Rizzi, L. 1978. 'A Restructuring Rule in Italian Syntax.' In S. J. Keyser, ed. *Recent Transformational Studies in European Languages*, pp. 113-158. Cambridge: MIT Press.
- Rooryck, J. 1994. 'On 0- and alpha- underspecification in syntax and phonology. The morphology-syntax connection.' In H. Harley and C. Phillips, eds. *MIT Working Papers in Linguistics 22*, pp. 197-216. Cambridge: MIT.
- Selkirk, E. 1977. 'Some Remarks on Noun Phrase Structure.' In P. Culicover, T. Wasow and A. Akmajian eds. *Formal Syntax*, pp. 285-316. San Diego: Academic Press.

- Sharvy, R. 1978. Maybe English Has No Count Nouns: Notes on Chinese Semantics. *Studies in Language* 2: 345-365.
- Sportiche, D. 1996. 'Clitic Constructions.' In J. Rooryck and L. Zaring, eds. *Phrase Structure and the Lexicon*, pp. 213-276. Dordrecht: Kluwer.
- Stowell, T. 1981. *Origins of Phrase Structure*. MIT Ph. Diss.
- Szabolcsi, A. 1983. The Possessor That Ran Away from Home. *The Linguistic Review* 3: 89-102.
- Szabolcsi, A. 1994. 'The Noun Phrase.' In F. Kiefer and K. É. Kiss, eds. *Syntax and Semantics 27: The Syntactic Structure of Hungarian*, pp. 179-274. San Diego: Academic Press.
- Takahashi, D. 1994. *Minimality of Movement*. University of Connecticut Ph. Diss.
- Torrego, E. 1998. *Dependencies of Objects*. Cambridge: MIT Press.
- Trithart, M. 1977. *Relational Grammar and Chichewa Subjectivization*. UCLA Ph. Diss.
- Ura, H. 1996. *Multiple Feature Checking: A Theory of Grammatical Function Splitting*. MIT Ph. Diss.
- Uriagereka, J. 1993. 'Specificity and the Name Constraint.' In C. Mason, S. Powers and C. Schmitt, eds. *University of Maryland Working Papers in Linguistics* 1, pp. 121-143. College Park: Department of Linguistics.
- Uriagereka, J. 1995. 'Warps: Some Thoughts on Categorization.' In R. Echeppare and V. Miglio, eds. *University of Maryland Working Papers in Linguistics* 3, pp. 256-308. College Park: Department of Linguistics.
- Uriagereka, J. 1996. 'From Being to Having.' In J. C. Castillo, V. Miglio and J. Musolino, eds. *University of Maryland Working Papers in Linguistics* 4, pp. 152-172. College Park: Department of Linguistics.
- Uriagereka, J. 1999a. 'Multiple Spell-Out.' In S. Epstein and N. Hornstein, eds. *Working Minimalism*, pp. 251-282. Cambridge: MIT Press.

- Uriagereka, J. 1999b. *We Need the Whole Nine Yards to Account for Romance Clitics*. University of Maryland Ms.
- Uriagereka, J. 2000. *In Defense of Deep-Structure*. University of Maryland Ms.
- Vergnaud, J. R. and M. L. Zubizarreta 1992. The Definite Determiner and the Inalienable Constructions in English and French. *Linguistic Inquiry* 23: 595-652.
- Williams, E. 1984. *There* Insertion. *Linguistic Inquiry* 15: 131-153.
- Winston, M., R. Chaffin and D. Herrmann 1987. A Taxonomy of Part-Whole Relations. *Cognitive Science* 11: 417-444.